

SMART DIFFERENTIAL PRESSURE TRANSMITTER APR-2000ALW



- ✓ 4...20 mA output signal + HART 5 / HART 7 protocol
(special version: 0...20 mA or 0...5 mA output signal + HART 5 protocol)
- ✓ Display with backlight
- ✓ Safety version SIL2/SIL3
- ✓ Intrinsic safety certificate ATEX, IECEx, FM (USA, Canada)
- ✓ Explosion proof certificate ATEX, IECEx, FM (USA, Canada)
- ✓ Programmable zero range, shift, characteristic and damping ratio with local panel keys
- ✓ Static pressure limit up to 600bar
- ✓ Accuracy 0,075% (0,05%, 0,04% on request)
- ✓ Marine certificate – DNV, BV
- ✓ Gold plated diaphragms
- ✓ Wetted parts material 316L/Hastelloy C276

up to 5 years warranty

static pressure limit up to 600bar

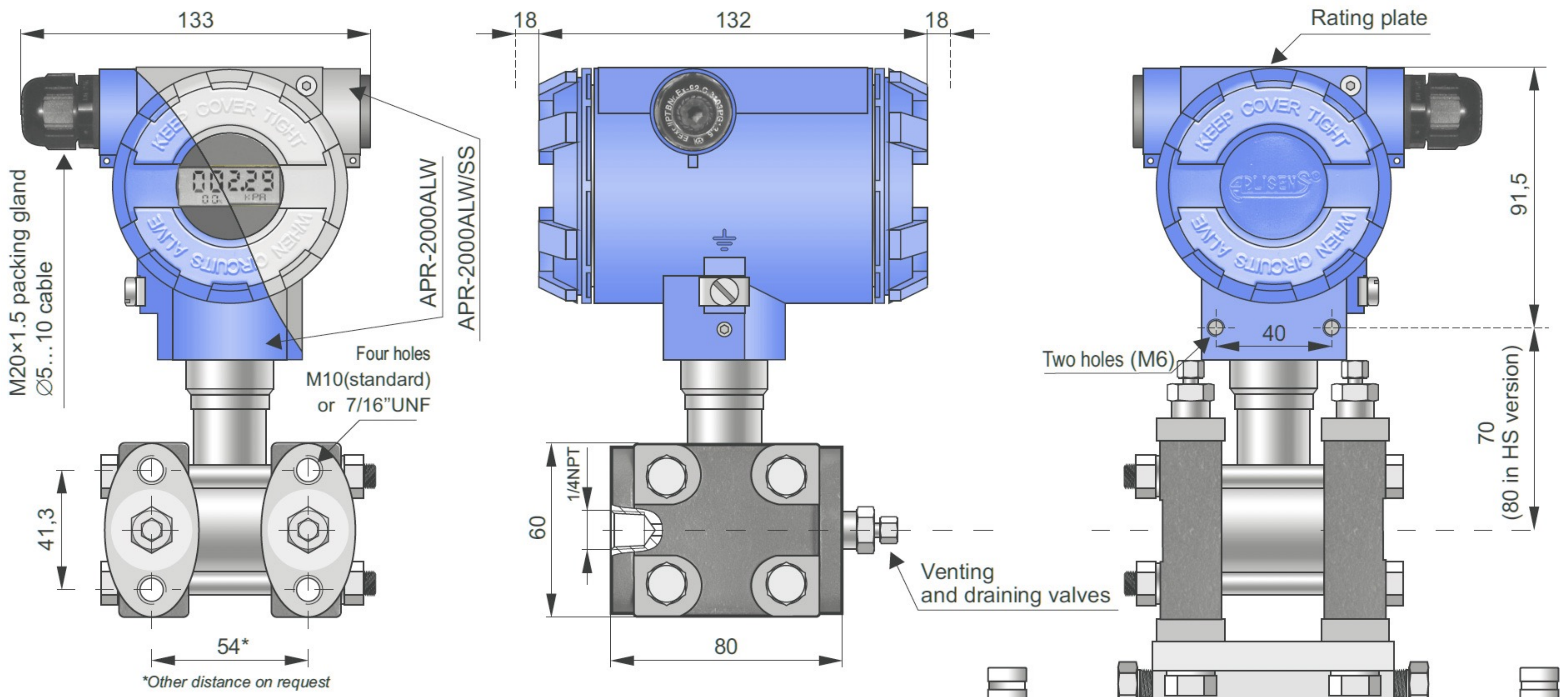

Transmitter **APR-2000ALW** – version with **type C** process connection to be mounted together with a valve manifold

Version with process connection rotated 90°

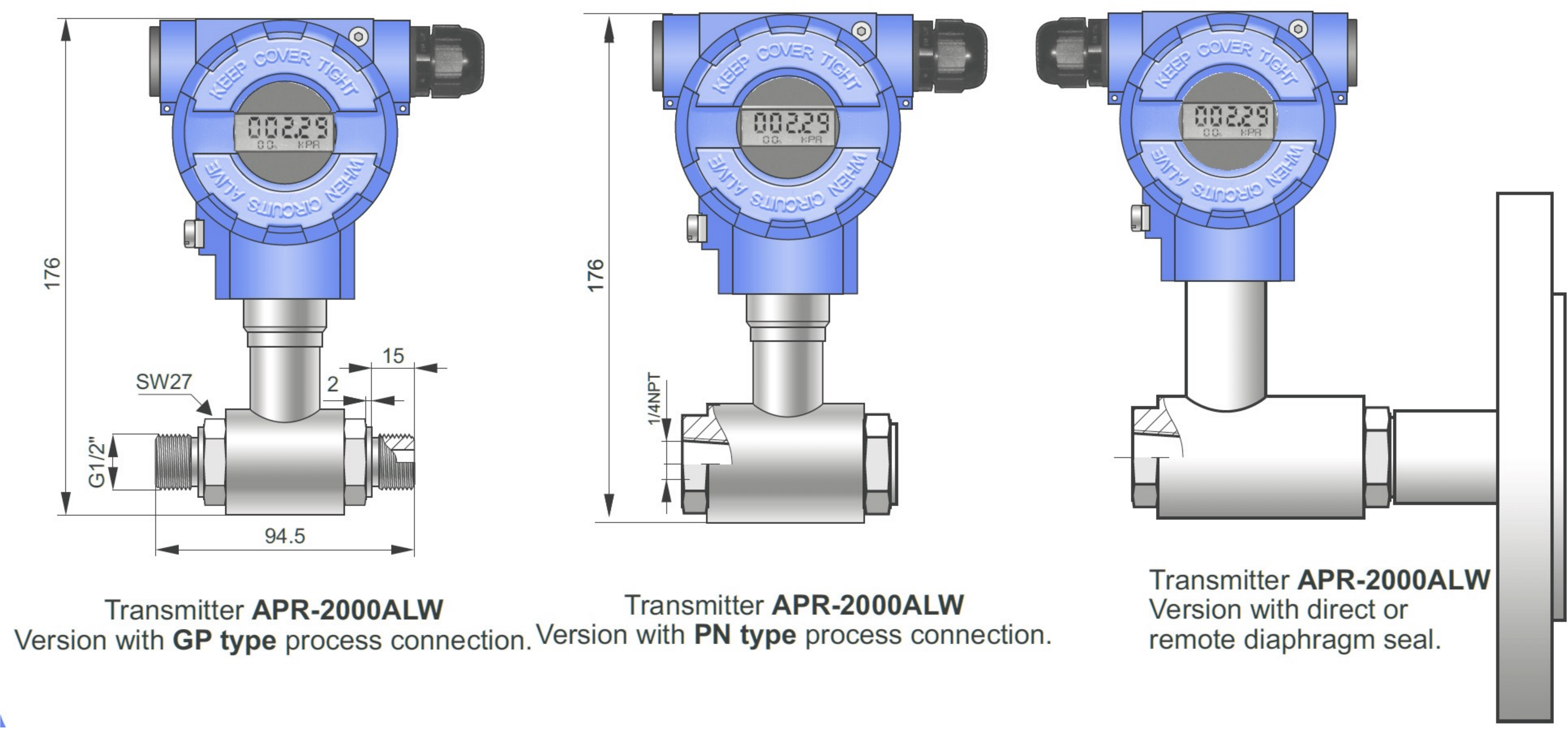

Transmitter **APR-2000ALW**
Version with **GP type** process connection.

Transmitter **APR-2000ALW**
Version with **PN type** process connection.

Transmitter **APR-2000ALW**
Version with direct or remote diaphragm seal.

Application and construction

The APR-2000ALW transmitter is applicable to the measurement of differential pressure of gases, vapours and liquids. The active element is a piezoresistant silicon sensor separated from the medium by separating diaphragms and a specially selected type of manometric fluid. The special design of the active sensing element ensures that it is able to withstand pressure surges and overloads of up to 2 0 3 0 bar. The casing is made of aluminium alloy cast or 316SS stainless steel, degree of protection IP6/IP67. The design of the casing enables the use of a local display, rotation of the display, rotation of the casing by 0–340° relative to the sensor, and a choice of cable direction.

Communication and configuration

The communication standard for data interchange with the transmitter is the Hart protocol.

Communication with the transmitter is carried out with:

- a KAP-03, KAP-03Ex communicator
- some other Hart type communicators(*)
- a PC using an HART/USB converter and Raport 2 configuration software.

(*) .eddl files available on www.aplisens.com.

The data interchange with the transmitter enables users to:

- ◆ identify the transmitter
- ◆ configure the output parameters:
 - measurement units and the values of the start points and end points at the measurement range
 - damping time constant
 - conversion characteristic (inversion, user's non-linear characteristic)
- ◆ read the currently measured pressure value of the output current and the percentage output control level
- ◆ force an output current with a set value
- ◆ calibrate the transmitter in relation to a model pressure

Installation

The transmitter with **P** or **PN Type** process connection is not heavy, so can be installed without additional mounting bracket on application. For fitting in any desired position we recommend an universal Aplisens mounting bracket for 2 pipe (AL mounting bracket, see page IV/ 5). The version with **C type** process connections can be fitted directly to a 3- or 5- valve manifold. We recommend factory-mounted transmitters with VM type valve manifold (page IV/ 2). A transmitter without a valve manifold can be fitted in any position on a 2 pipe or on a wall using the C-2 mounting bracket (page IV/ 5). When the special process connections are required for the measurement of specific media levels in closed tanks (e.g. in the sugar and chemical industries) the transmitter is fitted with an Aplisens diaphragm seal. Sets of differential pressure transmitters with diaphragm seals are described in detail in the further part of the catalogue.

Measuring ranges

No.	Nominal measuring range (FSO)	Minimum set range	Rangeability	Overpressure limit/ static pressure limit
1	0...70 bar (0...7 MPa)	7 bar (700 kPa)	10:1	C-type: 250 / 320 / 413 bar (250 bar for PED version) GP-type: 40 bar (for range no. 1: 70bar)
2	0...16 bar *	1,6 bar (160 kPa)	10:1	
3	0...2,5 bar (0...250 kPa)	0,2 bar (20 kPa)	12,5:1	
4	0...1 bar *	50 mbar (5k Pa)	20:1	
5	0...0,25 bar *	10 mbar (1k Pa)	25:1	
6	-0,5...0,5 bar * (-50...50 kPa)	0,1 bar (10 kPa)	10:1	
7	-100...100 mbar * (-10...10 kPa)	10 mbar (1 kPa)	20:1	
8	-5...70 mbar * (-0,5...7 kPa)	4 mbar (0,4 kPa)	18:1	
9	-25...25 mbar ** (-2,5...2,5 kPa)	2 mbar (0,2 kPa)	25:1	
10	-7...7 mbar ** (-700...700 Pa)	1 mbar (0,1 kPa)	14:1	

* available also in HS version

** available only in HS version

Technical data

Metrological parameters

Accuracy	≤ ±0,075% of the calibrated range
Special version:	≤ ±0,05% of the calibrated range (≤ ±0,04%, ≤ ±0,025% on request)
Long term stability (for the nominal measuring range)	≤ accuracy for 3 years or ≤ 2 x accuracy for 5 years HS version: ≤ accuracy for 10 years
Thermal error	< ±0,05% (FSO) / 10°C for ranges no. 1 - 9 < ±0,08% (FSO) / 10°C for ranges no. 10 max. ±0,25% (FSO) in the whole compensation range spec. version for ranges no 1-9: ≤ ±0,03% (FSO) / 10°C max. ±0,1% (FSO) in the whole compensation range
Thermal compensation range	-25...80°C
Zero shift error for static pressure	0,01% (FSO) / 10 bar for ranges no. 3, 4, 5, 6, 7, 9 0,03% (FSO) / 10 bar for range no. 8 0,06% (FSO) / 10 bar for ranges no. 1, 2 0,01% (FSO) / 10 bar for ranges no. 2, 8 in HS version 0,02% (FSO) / 10 bar for range no. 10
Zeroing the transmitter in conditions of static pressure can eliminate this error.	
Additional electronic damping	0...60 s
Error due to supply voltage changes	0,002% (FSO) / V

Electrical parameters

Version	Power supply
standard	10...55 VDC
Exia	10,5...30 VDC
IS	11,5...30 VDC
Exd, XP	13,5...55 VDC
Exia/Exd, IS/XP	11,5...30 VDC / 11,5...55 VDC
Safety, Safety Exd, Safety XP	11,5...36 VDC
Safety Exia, Safety IS	11,5...30 VDC
Safety Exia/Exd, Safety IS/XP	11,5...30 VDC / 11,5...36 VDC

Output signal 4...20 mA + HART

Load resistance (for standard version) $R(\Omega) \leq \frac{U_{sup} [V] - 10 V}{0,0225 A}$

Resistance required for communication min. 240 Ω

Materials

Wetted parts	type GP, PN: SS316L type C: SS316L (Hastelloy C276 on request)
Diaphragms	SS316L (Hastelloy C 276, Tantalum, Au on request)
Casing	Aluminium Option: SS316 Material of window: hardened glass

Operating conditions

Operating temperature range (ambient temp.)	-25...85°C
	Exia, IS version: -25...80°C
	Exd, XP version: -25...75°C
Medium temperature range	-25...120°C
	Safety, 600bar version: -25...85°C
	PED, 413bar version: -25...100°C
over 120°C – measurement with use an impulse line or diaphragm seals	

CAUTION: the medium must not be allowed to freeze in the impulse line or close to the process connection of the transmitter

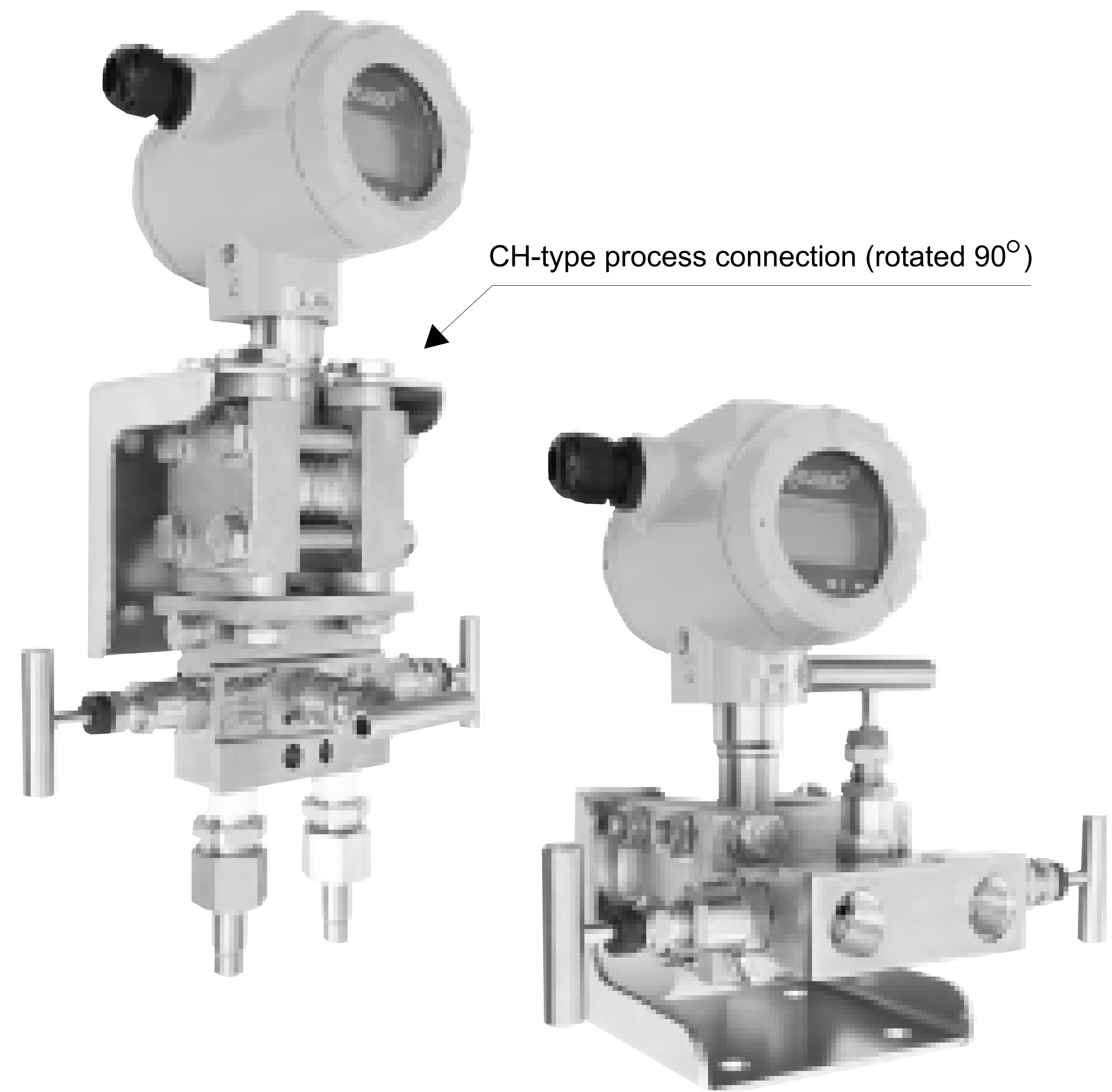

Ordering procedure

Model	Code	Description
APR-2000		Smart differential pressure transmitter
Versions	/ALW..... /ALW/Safety.....	With display, output 4-20mA + Hart Functional Safety certificate according to PN-EN61508:2010 parts 1+7, PN-EN 61511-1:2017 + PN-EN 61511-1:2017/A1:2018-03, PN-EN 62061:2008 + PN-EN 62061:2008/A1:2013-06 + PN-EN 62061:2008/A2:2016-01
Certificates, options*	/SS.....	Stainless steel housing
	/Exia.....	II 1/2G Ex ia IIC T4/T5 Ga/Gb IECEX Ex ia IIC T4/T5 Ga/Gb
	/Exia (Da).....	II 1/2G Ex ia IIC T4/T5 Ga/Gb II 1D Ex ia IIIC T105°C Da I M1 Ex ia I Ma (version with SS housing) Ex ia IIC T4/T5 Ga/Gb IECEX Ex ia IIIC T105°C Da Ex ia I Ma (version with SS housing)
	/IS.....	IS Class I, Div 1, Groups A, B, C, D T4 IS Class II, Div 1, Groups E, F, G T5 IS Class III, Div 1, T5 Zone 0 AEx/Ex ia IIC T4 Ga Zone 20 AEx/Ex ia IIIC T105°C Da
	/Exd.....	II 1/2G Ex ia/db IIC T6/T5 Ga/Gb II 1/2D Ex ia/tb IIIC T105°C Da/Db I M2 Exd ia I Mb (version with SS housing) Ex ia/db IIC T6/T5 Ga/Gb IECEX Ex ia/tb IIIC T105°C Da/Db Ex db ia I Mb (version with SS housing) Packing gland available on request
	/Exd (2G).....	II 2G Ex ia/db IIC T6/T5 Gb II 2D Ex ia/tb IIIC T105°C Db Ex ia/db IIC T6/T5 Gb IECEX Ex ia/tb IIIC T105°C Db Packing gland available on request
	/XP.....	XP Class I, Div 1, Groups A, B, C, D T5 DIP Class II, Div 1, Groups E, F, G T5 DIP Class III, Div 1, T5 Zone 1 AEx db ia IIC T5 Gb Zone 21 AEx ia tb IIIC T105°C Db Packing gland available on request
	/XPC.....	XP Class I, Div 1, Groups B, C, D T5 DIP Class II, Div 1, Groups E, F, G T5 DIP Class III, Div 1, T5 Zone 1 AEx/Ex db ia IIC T5 Gb Zone 21 AEx/Ex ia tb IIIC T105°C Db Packing gland available on request
	/Exia(Da)/Exd.....	Dual certification Exia(Da) and Exd
	/Exia(Da)/Exd(2G).....	Dual certification Exia(Da) and Exd(2G)
	/IS/XP.....	Dual certification IS and XP for US
	/IS/XPC.....	Dual certification IS and XPC for US and Canada
	/SA.....	Surge arrester for Exia version
/PED.....	PED category I (only process connection type C)	
/HS.....	Ultra stable version (only ranges no. 2, 4+10)	
/0.05%	Accuracy $\leq \pm 0,05\%$	
/MR.....	Marine certificate – DNV, BV	
/Tlen.....	For oxygen service (sensor filled with Fluorolube fluid)	
/320 bar.....	Static pressure 320 bar, only for C process connection, not available in P ED version	
/413 bar.....	Static pressure 413 bar, only for C process connection, not available in P ED version	
/600 bar.....	Static pressure 600 bar, only for C process connection, not available in P ED version	
	Execution on request – please consult availability with manufacturer	
/IP67.....	Protection class IP67	
/NACE.....	NACE MR-01-75 certificate (only process connection type C)	
/Hart 7.....	Communication protocol HART in revision 7	

* more than one option is available

See next page

Code		Description	
		Range	Min. set range
Nominal measuring ranges	/0÷70 bar.....	0÷70 bar (0÷7000 kPa)	7 bar (700 kPa)
	/0÷16 bar.....	0÷16 bar (0÷1600 kPa)	1,6 bar (160 kPa)
	/0÷2,5 bar.....	0÷2,5 bar (0÷250 kPa)	0,2 bar (20 kPa)
	/0÷1 bar.....	0÷1 bar (0÷100 kPa)	50 mbar (5 kPa)
	/0÷0,25 bar.....	0÷0,25 bar (0÷25 kPa)	10 mbar (1 kPa)
	/-0,5÷0,5 bar.....	-0,5÷0,5 bar (50÷50 kPa)	0,1 bar (10 kPa)
	/-0,1÷0,1 bar.....	-0,1÷0,1 bar (-10÷10 kPa)	10 mbar (1 kPa)
	/-5÷70 mbar.....	-5÷70 mbar (0,5÷7 kPa)	4 mbar (0,4 kPa)
	/-25÷25 mbar.....	-25÷25 mbar (-2,5÷2,5 kPa)	2 mbar (0,2 kPa)
/-7÷7 mbar.....	-7÷7 mbar (-0,7÷0,7 kPa)	1 mbar (0,1 kPa)	
Measuring set range	/...+... [required units]	Calibrated range in relation to 4mA and 20mA output	
Process connections	/C.....	Thread 1/4NPT F on the cover flanges cover flanges. Allows mounting with a valve manifold. Process connection of cover flange: M10 (option /C(7/16) - 7/16"UNF acc. to IEC 61518), wetted parts material: choose below	
	/CH.....	C-type process connection rotated 90°	
	/GP.....	Thread G1/2" (male), wetted parts material: SS316L	
	/PN.....	Thread 1/4"NPT (female), wetted parts material: SS316L	
	/code of diaphragm seal.....	Diaphragm seal (see chapter of diaphragm seals) mounted on Hi side of transmitter, Lo side 1/4NPT Female	
Material of wetted parts: (diaphragms/covers) (refers only to C, CH process connection)	(without marking).....	Covers material: SS316L / Diaphragms material: SS316L	
	/(316L/Hast).....	Covers material: SS316L / Diaphragms material: Hastelloy C276	
	/(Hast/Hast).....	Covers material: Hastelloy C276 Cast / Diaphragms material: Hastelloy C276	
	/(316L/Au).....	Covers material: SS316L / Diaphragms material: Gold plated	
	/(316L/Ta).....	Covers material: SS316L / Diaphragms material: Tantalum	
Gasket (refers only to C, CH process connection)	(without marking).....	FPM Viton (not available for Hast/Hast, Ta/316L and Ta/Hast versions)	
	/NBR.....	NBR (not available for Hast/Hast, Ta/316L and Ta/Hast versions)	
	/PTFE.....	PTFE	
Electrical connection	(without marking)	Packing gland M20x1,5	
	/US.....	Thread 1/2"NPT Female	
Accessories	/C-2".....	Mounting bracket for 2" pipe (to C process conn.), mat. zinc steel	
	/C-2"(SS).....	Mounting bracket for 2" pipe (to C process conn.), mat. ss304	
	/C-2"(SS316)...	Mounting bracket for 2" pipe (to C process conn.), mat. ss316	
	/C-2"B.....	Mounting bracket for 2" pipe (to C(7/16) process conn.), mat. zinc steel	
	/C-2"B(SS).....	Mounting bracket for 2" pipe (to C(7/16) process conn.), mat. ss304	
	/C-2"B(SS316)...	Mounting bracket for 2" pipe (to C(7/16) process conn.), mat. ss316	
	/FI25.....	Mounting bracket for 1" pipe (to P process conn.), mat. Stainless Steel	
	/RedSpaw GP..	Connector to weld impulse pipes dia. 12 and 14 mm, material 15HM(SO) or SS316(S). Only process connection GP type	
	/RedSpaw C....	Connector to weld impulse pipes dia. 12 and 14 mm, material 15HM. Only process connection C type.	
	/Red d/P 1/2"...	Adapter for differential pressure transmitters with C type process connection, output thread 1/2NPT F. Material SS316L	
/ST.....	Stainless Steel plate fixed to the housing		
/MT.....	Stainless Steel Tag plate mounted on wire		
Other specification	/.....	Description of required parameters	

Standard display configuration

	Std. version	Exia, Exia(Da)	IS	Exd	XP	Exia(Da)/Exd, IS/XP	Safety
Backlight on	•	•			•		
Backlight off			•			•	•

Other configuration of display has to be marked upon placing order. User has no possibility of switching backlight on/off.