

Temperature sensor for high temperature applications

- ✓ - TC sensors J, K, S, B
- ✓ - ATEX Exia certificate

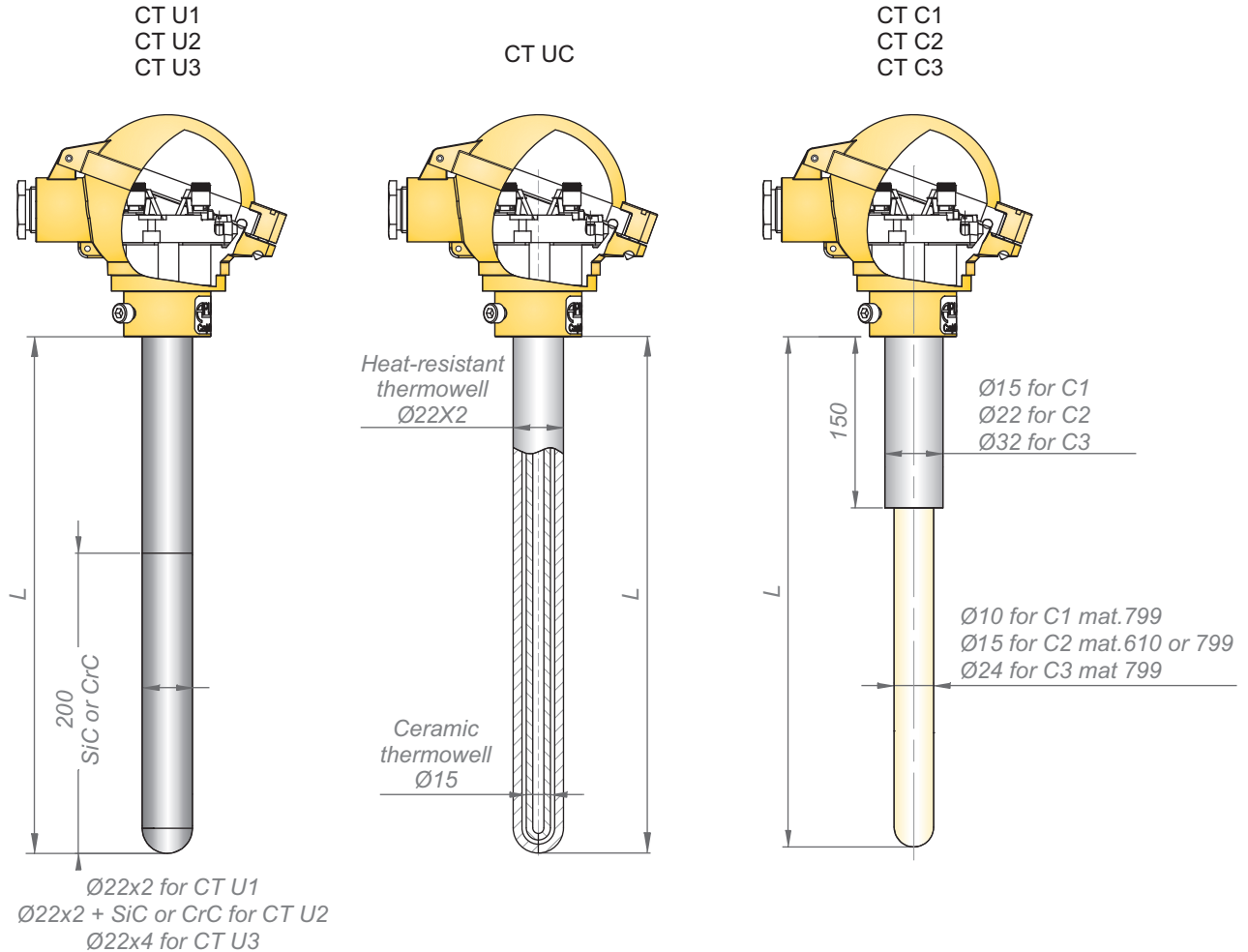

Features

Temperature sensors CT C, CT U, are offered as thermocouples.

Thermocouples are made of two different conductors joined at the end. The temperature difference between junction, placed in measuring point (hot junction), and wire ends (cold junction), generate voltage proportional to the difference of temperature between these junctions. Thermocouples are suitable for the measurement of high temperatures, up to 1700°C.

The accuracy classes 1 and 2 are available with tolerance acc. to IEC60584

Description

Temperature sensors model CTC and CTU are designed for high temperatures up to 1700°C. Various wetted parts materials like heat resistant stainless steel, ceramic or sialon allow to cover many high temperature applications.

Sensors are offered with various fitting elements.

Typical application are:

- chemical application,
- metal alloys industry

Ordering procedure			
CT			
Process part			
	U1		
	U2		
	U3		
	C1		
	C2		
	C3		
Certificate			
	x		standard version, no certificates
	Exia /II		II 1/2 G Ex ia IIC T6...T1 Ga/Gb II 1D Ex ia IIIC T75°C Da
Measuring element			
	J		TC type J
	2xJ		2x TC type J
	K		TC type K
	2xK		2xTC type K
	S		TC type S
	2xS		2xTC type S
	B		TC type B
	2xB		2xTC type B
Class of element			
	1/O		TC sensor, Class 1, ungrounded junction
	2/O		TC sensor, Class 2, ungrounded junction
Length			
	L=		required length of immersion [mm]
	S, L1, L2...=...		required length of immersion end extension [mm] – only CT-F
Process connection			
	X		Without clamping grip
	UC1-22		
	UC2-22		