

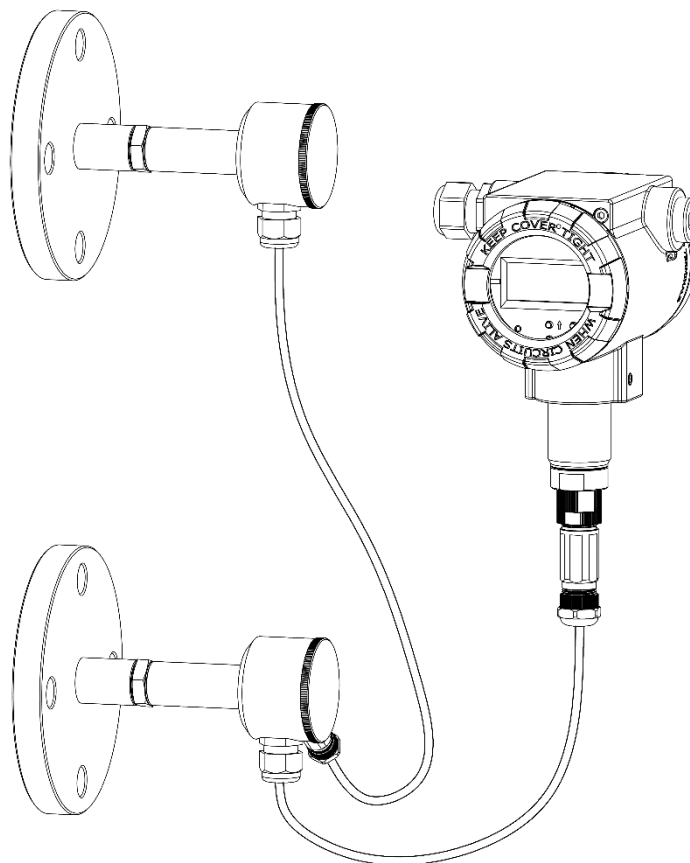

USER'S MANUAL

INTELLIGENT, MODULAR DIFFERENTIAL PRESSURE
TRANSMITTERS

APM-2



PRODUCT CODE – see → [5.2. Transmitter identification.](#)

The QR code or ID number identifies the transmitter and provides quick access to the following documentation on the manufacturer's website: user's manual, explosion-proof device user manual, technical information, declarations of conformity and copies of certificates.

APM-2

ID:0029 0001 0002 0000 0000 0000 0001 97

<https://www.aplisens.pl/ID/002900010002000000000000000000197>

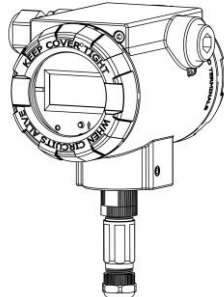

APM-2 (Exi)

ID:0029 0002 0002 0000 0000 0001 0001 17

<https://www.aplisens.pl/ID/00290002000200000000000000001000117>

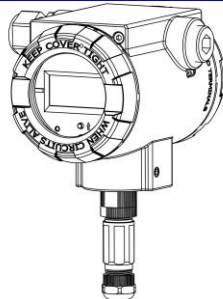



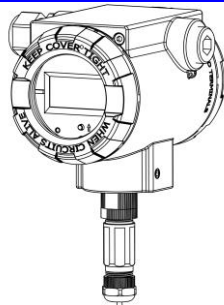

APM-2 (Exd)

ID:0029 0003 0002 0000 0000 0002 0001 34

<https://www.aplisens.pl/ID/00290003000200000000000000002000134>



Symbols used

Symbol	Description
	Warning to proceed strictly in accordance with the information contained in the documentation in order to ensure the safety and full functionality of the device.
	Information particularly useful during installation and operation of the device.
	Information particularly useful during installation and operation of an Ex type device.
	Information on disposal of used equipment.

BASIC REQUIREMENTS AND SAFE USE



The manufacturer will not be liable for damage resulting from incorrect installation, failure to maintain suitable technical condition of the device or use of the device other than for its intended purpose.

Installation should be carried out by qualified staff having the required authorizations to install electrical and I&C equipment. The installer is responsible for performing the installation in accordance with manual as well as with the electromagnetic compatibility and safety regulations and standards applicable to the type of installation.

All safety and protection requirements must be observed during installation, operation and inspections.

If a malfunction occurs, the device should be disconnected and handed over to the manufacturer for repair.



In order to minimize the risk of malfunction and associated risks to staff, the device is not to be installed or used in particularly unfavourable conditions, where the following hazards occur:

- possible mechanical impacts, excessive shocks and vibration;
- excessive temperature fluctuation;
- water vapour condensation, dusting, icing.



Installation of the transmitter in explosion-risk atmospheres must comply with the requirements of relevant instructions and national standards and regulations.

Changes made to the manufacturing of products may be introduced before the paper version of the manual is updated. The up-to-date manuals are available on the manufacturer's website: www.aplisens.com.

TABLE OF CONTENTS

1. INTRODUCTION	6
1.1. Purpose of the document.....	6
1.2. Trademarks	6
1.3. Definitions and abbreviations	7
1.4. Transmitter set range.....	8
2. SAFETY	8
3. TRANSPORT AND STORAGE	9
3.1. Delivery check	9
3.2. Transport	9
3.3. Storage.....	9
4. GUARANTEE.....	9
5. IDENTIFICATION	10
5.1. Manufacturer's address	10
5.2. Transmitter identification.....	10
5.3. CE mark, declaration of conformity	10
6. INSTALLATION	11
6.1. Installation manual for the APM-2 system	11
6.2. Example of transmitter installation	11
6.3. Closing of housing covers, sealing.....	12
7. ELECTRICAL CONNECTION	13
7.1. Cable connection to central unit HUB	13
7.1.1. Connection of power supply cable – current loop to the internal terminals of the HUB central unit.....	13
7.1.2. Connection of pressure transmitters PC1 and PC2 to the communication connector of the HUB central unit	14
7.1.3. Connection of APM-2 with option of using local HART 7 communication.....	14
7.2. Power supply APM-2 system	16
7.2.1. Central unit HUB supply voltage.....	16
7.2.2. Uninterruptible current measurement in 4 ... 20 mA current loop	17
7.2.3. Specifications of electrical switching terminals	17
7.2.4. Cabling specification	17
7.2.5. Resistance load in power supply line.....	17
7.2.6. Shielding	17
7.3. Equipotential bonding	18
7.4. Overvoltage protection.....	18
7.5. Final inspection of cabling.....	18
8. START-UP	19
8.1. Alarm configuration.....	19
8.2. Configuration of operating mode.....	20
8.3. Correction of impact of transmitter mounting position on site – pressure reset.....	21
8.4. Entry of process range by applied process value	21
8.5. Differential pressure measurements	21
8.6. Level measurements	21
8.7. Flow measurements	22
9. OPERATION	23
9.1. LCD display	23
9.2. Abbreviations of error codes of local interface configuration options and their descriptions:	27
9.3. Local buttons	27
9.4. Local configuration of setpoints.....	27
9.5. Navigation in local setpoints MENU	27
9.6. Acceptance of local setpoints.....	28
9.7. Structure of local setpoints MENU	28
9.8. HELP mode structure.....	29

9.9. Remote configuration of setpoints (HART)	30
9.9.1. Compatible devices	30
9.9.2. Compatible configuration software	30
9.9.3. Local HART communication jumper	30
10. MAINTENANCE	31
10.1. Periodic inspections	31
10.2. Non-periodic inspections	31
10.3. Cleaning/washing	31
10.3.1. Diaphragm cleaning	31
10.4. Spare parts	31
10.5. Repair	31
10.6. Returns	31
11. SCRAPPING, DISPOSAL	32
12. HISTORY OF REVISIONS	32

LIST OF DRAWINGS

Figure 1. Set range and measurement limits	8
Figure 2. Examples of APM-2 installation on tanks	11
Figure 3. Central unit sealing principle	12
Figure 4. Electrical connection to central unit HUB	13
Figure 5. Cable connector PM12 type	14
Figure 6. Electrical connection 4 ... 20 mA of HART to APM-2 system in standard version	15
Figure 7. Electrical connection 4 ... 20 mA of HART to APM-2 system in Exd version	15
Figure 8. Electrical connection 4 ... 20 mA of HART to APM-2 system in Exi version	16
Figure 9. Electrical ammeter connection	17
Figure 10. Set range current, saturation currents, alarm currents	19
Figure 11. Rotation of the housing, change of display position and access to buttons	23
Figure 12. Display information fields	23

LIST OF TABLES

Table 1. Definitions and abbreviations	7
Table 2. Symbols occurring on the central unit HUB, pressure transmitters nameplate	10
Table 3. Permissible APM-2 supply voltages	16
Table 4. APM-2 HELP mode structure	29

1. INTRODUCTION

1.1. Purpose of the document

The subject of manual is intelligent, modular differential pressure transmitters **APM-2**.

The system consists of a central unit (HUB) and two measuring transmitters with the same serial numbers as the central unit. The manual applies to the following versions: standard, PED, flameproof Exd, intrinsically safe Exi.

Within the meaning of Directive 2014/68/EU (PED), the transmitters are designed to category I, module A. PED marking does not apply to additional equipment of the transmitters, i.e. separators, valves, connectors, impulse tubes, etc. In the manufacturer's EU declarations of conformity, the transmitters as designed above have the CE markings. The transmitters with permissible overload of 200 bar and lower are manufactured in accordance with good engineering practice according to article 4 point 3 of Directive 2014/68/EU.

The manual contains data, tips and general recommendations for safe installation and operation of the APM-2 system, as well as troubleshooting in case of possible failure.

The manual does not cover explosion protection issues.



The use of the equipment in hazardous zones without appropriate approvals is forbidden. It is mandatory to read EN.IX.APM.2 Explosion-proof Device User Manual, containing important information related to the installation of intrinsically safe and flameproof versions of the APM-2.

1.2. Trademarks

HART® is a registered trademark of FieldComm Group.

Windows® is a registered trademark of Microsoft Corporation.

Google Play® is a service registered and managed by Google® Inc.

1.3. Definitions and abbreviations

Table 1. Definitions and abbreviations

Item No.	Abbr.	Meaning
1	LRV	„Lower Range Value” - value of set range limit assigned to 4 mA output current value, or to value of 0% of set range, defined in physical units. Set range limits cannot exceed base range limits of APM-2 device. By default the set range limit values are set to base range limits (LRV=LRL and URV=URL). Minimal span of set range (URV-LRV) is limited by software to 1kPa.
2	URV	„Upper Range Value” - value of set range limit assigned to 20 mA output current value, or to value of 100% of set range, defined in physical units. Set range limits cannot exceed base range limits of APM-2 device. By default the set range limit values are set to base range limits (LRV=LRL and URV=URL). Minimal span of set range (URV-LRV) is limited by software to 1kPa.
3	LRL LTL	„Lower Range Limit” or „Lower Transmitter Limit” - value of lower limit of base range, defined in physical units. Value (URL-LRL) or (UTL-LTL) is defined as base range of APM-2. This limit value is a dependant on sensor’s operating capabilities. When process value is equal or less than LRL, a PrimaryVariableOutOfLimits, NonPrimaryVariableOutOfLimits or PvOutOfLimit statuses of PC1/ PC2 status groups are set by APM-2.
4	URL UTL	„Upper Range Limit” or „Upper Transmitter Limit” - value of upper limit of base range, defined in physical units. Value (URL-LRL) or (UTL-LTL) is defined as base range of APM-2. This limit value is a dependant on Sensor’s operating capabilities. When process value is equal or greater than URL, a PrimaryVariableOutOfLimits, NonPrimaryVariableOutOfLimits or PvOutOfLimit statuses of PC1/ PC2 status groups are set by APM-2.
5	LPL	„Lower Processing Limit” – lower limit of digital signal processing. Transmitter limits the processing range to exact value of 50% of base range below lower base range limit LRL(LTL). When process value is between LPL and LSAL limits, transmitter halts digital signal processing of specified process variable and sets the DvOutOfProcessingLimit status of Other status group.
6	UPL	„Upper Processing Limit” – upper limit of digital signal processing. Transmitter limits the processing range to exact value of 50% of base range above upper base range limit URL(UTL). When process value is between UPL and USAL limits, transmitter halts digital signal processing of specified process variable and sets the DvOutOfProcessingLimit status of Other status group.
7	LSAL	„Lower Saturation Limit” – Lower limit of sensor’s processing capabilities. Value of this limit is less than LPL and is related to the lowest measurable process value. The accurate value of this limit cannot be specified, yet it should not be less than 200% of base range value below Lower Processing Limit LPL. When process value reaches range below LSAL, APM-2 sets the BufC0LimitError or BufC2LimitError status of PC1 or PC2 status group.
8	USAL	„Upper Saturation Limit” – Upper limit of sensor’s processing capabilities. Value of this limit is greater than UPL and is related to the highest measurable process value. The accurate value of this limit cannot be specified, yet it should not be greater than 200% of base range value above Upper Processing Limit UPL. When process value reaches range greater than USAL, APM-2 sets the BufC0LimitError or BufC2LimitError status of PC1 or PC2 status group.

1.4. Transmitter set range

The figure below shows the APM-2 set range and limits related to allowable set range, digital processing range and saturation limits of A/D pressure measurement transmitter. As standard, values of 4 mA/20 mA currents are assigned to LRV/URV points. In order to obtain reverse characteristics, it is possible to reverse the assignment so that the LRV/URV points are assigned to 20 mA/4 mA currents.

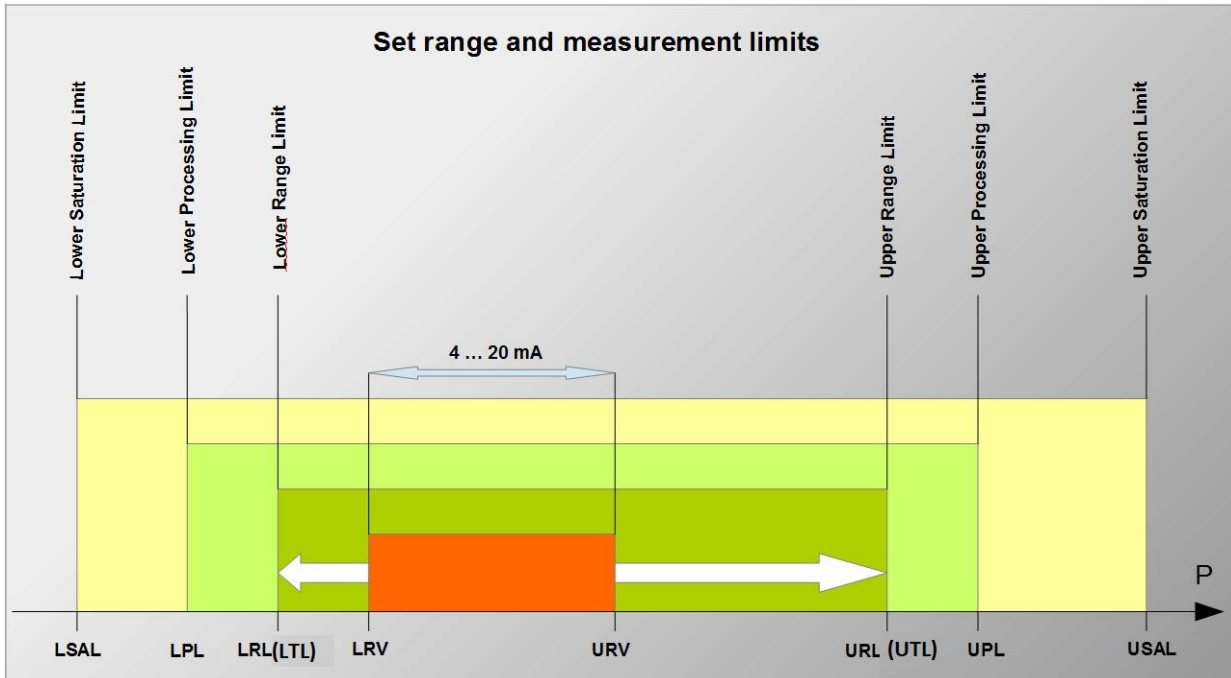

Figure 1. Set range and measurement limits

2. SAFETY

- The installation and start-up of the APM-2 system and any activities related to operation shall be carried out after thorough examination of the contents of user's manual and instructions related thereto.
- Installation and maintenance should be carried out by qualified staff having the required authorizations to install electrical and measuring devices.
- The device shall be used according to its intended purpose in line with the permissible parameters specified on the nameplate (→ [5.2 Transmitter identification](#)).
- The protection elements used by the manufacturer to ensure transmitter safety may be less effective if the device is operated in a manner not consistent with its intended purpose.
- Before installing or disassembling the device, it is absolutely necessary to disconnect it from the power source.
- No repairs or alterations to the transmitter electronic APM-2 system are permitted. Assessment of damages and possible repair may only be performed by the manufacturer or authorized representative.
- Do not use instruments if damaged. In case of malfunction, the device must be put out of operation.



3. TRANSPORT AND STORAGE

3.1. Delivery check

After receiving the delivery of the equipment, it is necessary to:

- make sure that the packaging and its contents were not damaged during transport;
- check the completeness and correctness of the received order, and make sure no parts are missing.

3.2. Transport

Transport of APM-2 system shall be carried out with the use of covered means of transport, in original packages with diaphragm provided with protection. The packaging shall be protected against movement and direct impact of atmospheric factors.

3.3. Storage

APM-2 system shall be stored in a factory packaging, in a room without vapours and aggressive substances, protected against mechanical impact.

Allowable range of storage temperature:

-40 ... 80°C (-40 ... 176°F).

4. GUARANTEE

General terms and conditions of guarantee are available on the manufacturer's website:

www.aplisens.com/ogolne_warunki_gwarancji



The guarantee shall be repealed if the device is used against its intended use, failure to comply with user's manual or interference with the structure of the device.

5. IDENTIFICATION









5.1. Manufacturer's address

APLISENS S.A.
03-192 Warsaw
Morelowa 7 St.
Poland

5.2. Transmitter identification

Depending on the version of the transmitter, the nameplates may differ in the amount of information and parameters.

Table 2. Symbols occurring on the central unit HUB, pressure transmitters nameplate

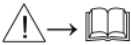
	Logo and name of manufacturer
	CE mark
	CE mark with the number of notified body
Aplisens S.A. ul. Morelowa 7, 03-192 Warszawa	Manufacturer address
	QR code
TYPE:	Type of device, electrical and process connection
ID	APM-2 model ID
# S/N	Serial number of transmitter
 P	Base measuring range
 U	Supply voltage values
	Output signal
 Tamb	Permissible range of ambient temperature
 PS	Maximum static pressure
IP	IP range value
Year of production	Year of production
	Note about the read the manual
//lower part of the nameplate//	Special execution
PC1/PC2	Designation of measuring transmitters

5.3. CE mark, declaration of conformity

The device has been designed to meet the highest safety standards, has been tested and has left the factory in a condition that is safe for operation. The device complies with the applicable standards and regulations listed in the EU Declaration of Conformity and has CE marking on nameplate.

6. INSTALLATION

6.1. Installation manual for the APM-2 system

Central unit HUB can be mounted in any position (→ 7.5 Final inspection of cabling). The housing of the transmitter should be protected against hot air streams by appropriate location of the transmitter or by installing thermal screens so that the transmitter does not heat up to a temperature higher than the permissible one. The HUB's housing allows for wall and pipe mounting. For this purpose, use the AL handle by Aplisens S.A. By default, function of high pressure transmitter is designed for PC1 pressure transmitter directly connected with central unit (to change the assignment, see → 8.2. Configuration of operating mode).

The mounting position of the transmitters may cause the zero point to shift (→ 8.3 Correction of impact of transmitter mounting position on site – pressure reset).



The place of installation should be selected so as to ensure sufficient relief of the cable tension in order to avoid their excessive bending. The cable must be mech-chained to the cable path (it must not hang on the transmitter connector).

The protection of the separator diaphragm can only be removed shortly before installation. Do not clean or touch the separator diaphragms using hard or pointy objects. Incorrect installation of the sealing may result in incorrect measurement indications. Special attention must be paid when selecting correct dimensions of the sealing.



As standard, the separators are not provided with the gaskets.

6.2. Example of transmitter installation

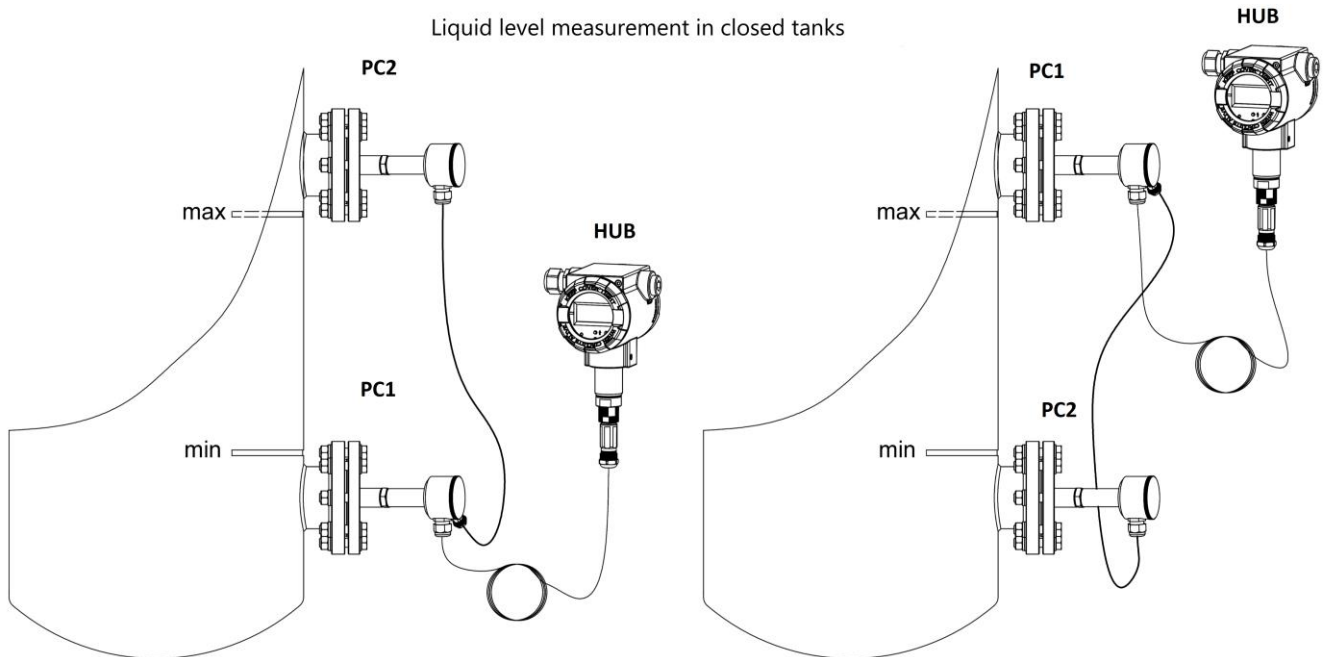

Figure 2. Examples of APM-2 installation on tanks

6.3. Closing of housing covers, sealing

The front and rear cover threads have a factory coating, therefore no additional coating is required. Before tightening the covers, make sure that the thread surfaces are free of contamination, e.g. sand. It should be possible to screw the covers smoothly. If resistance is felt when tightening, on the thread there is probably dirt which must be removed before tightening.



The central unit HUB and pressure transmitters housing does not provide tightness if the housing or covers thread is damaged.

Some transmitter applications require an interlock and sealing of covers to prevent unauthorized access to settings and adjustments. The method of sealing transmitters is shown in the figure below.

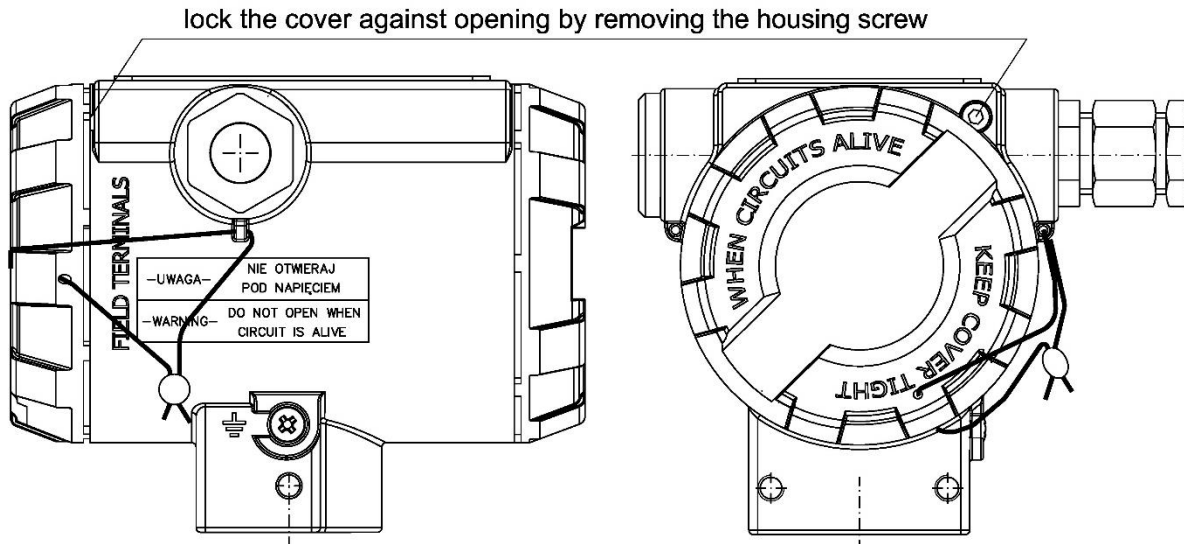

Figure 3. Central unit sealing principle

7. ELECTRICAL CONNECTION

7.1. Cable connection to central unit HUB



All connection and installation operations must be performed with disconnected supply voltage and other external voltages, if used.



Failure to provide proper connection of the APM-2 may result in danger. Risk of electric shock and/or ignition in potentially explosive atmospheres.

7.1.1. Connection of power supply cable – current loop to the internal terminals of the HUB central unit

In order to perform correct connection of the cables, the following steps shall be performed:

- disconnect power supply of the supply cable line;
- unscrew the rear cover of the HUB body to access the power connector;
- pull the cable through the cable gland;
- connect the HUB according to the figure below, paying attention to the correct tightening of the bolts fixing the conductor core to the terminal;
- check the correct fixing of the HART local communication jumper;
- tighten the rear cover of the HUB body;
- leaving a small clearance of the cable inside the body, tighten the gland nut so that the gland seal is clamped on the power cable.

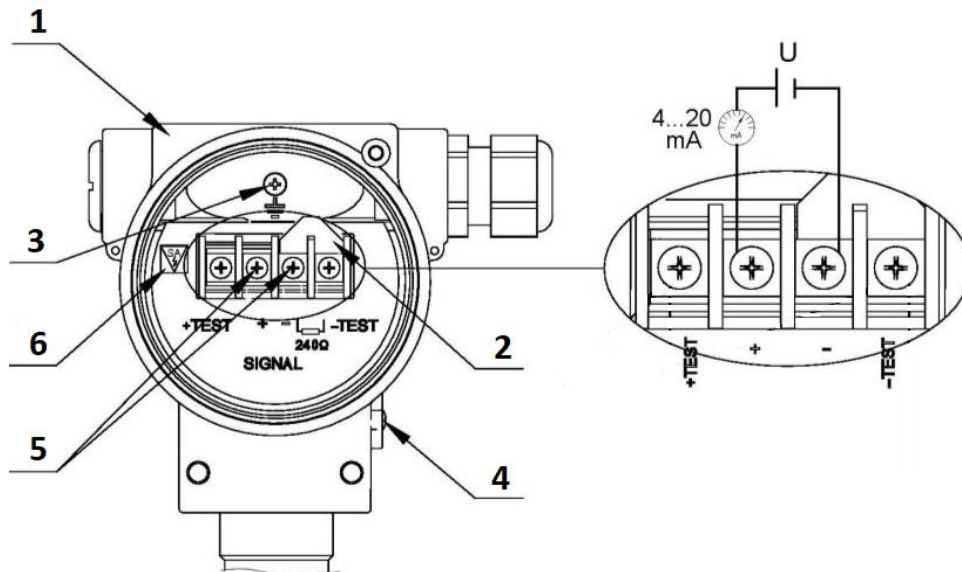

Figure 4. Electrical connection to central unit HUB

1. Housing.
2. Jumper for local HART communication.
3. Internal ground terminal.
4. External ground terminal.
5. Transmitter power terminals, 4 ... 20 mA current loop.
6. Designation SA variant with integrated overvoltage protection (applies to Exi version).

7.1.2. Connection of pressure transmitters PC1 and PC2 to the communication connector of the HUB central unit

Connect up the sensor labelled as PC1 to transmitter with PC1 BUS cable terminated with PM12 industrial connector and then connect up the other sensor, labelled as PC2, to PC1 sensor with PC2 BUS cable terminated with PM12 industrial connector. Both connected sensors must have the same serial number as the transmitter. BUS cables should be laid at least 0.5 meter apart from any other cables, that may be a source of electromagnetic interference, or should be put in separate shielded cable tray. When mounting the BUS cable on site, it is required to avoid any excessive cable stressing, bending or free-hanging. Minimal bending radius of thoroughly mounted cable must not exceed 50 mm. If cable cannot be completely immobilized, the minimum bending radius must not exceed 120 mm.

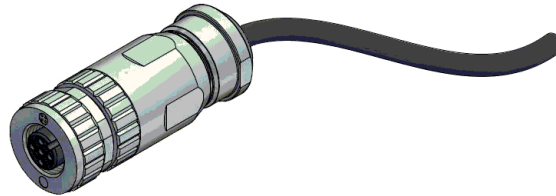

Figure 5. Cable connector PM12 type

Correctly connected BUS of the APM-2 system shows → [Figure 2. Examples of APM-2 installation on tanks.](#)



In hazardous zone, do not unscrew the housing covers after connecting the Exd flame-proof transmitter to the power source.

7.1.3. Connection of APM-2 with option of using local HART 7 communication

The system allows to use the local HART communication. To do this you can use a HART communicator unit or modem connected to a computer or a smartphone.

In order to establish the local communication, it is necessary to:

- remove HART communication jumper (item 2);
- connect the communicator or modem to electrical terminals (item 7).



Opening of the HART jumper results in applying resistance of 240 Ω in series in line 4 ... 20 mA. This resistance reduces voltage on system supply terminals by approximately 5 V DC for maximum current that can be set by the APM-2. To avoid the supply voltage deficit on the transmitter terminals, the HART jumper must be dismantled only for the time of performing the HART local communication.

Connection diagram of the communicator or modem to transmitter power supply and measurement system is presented below:

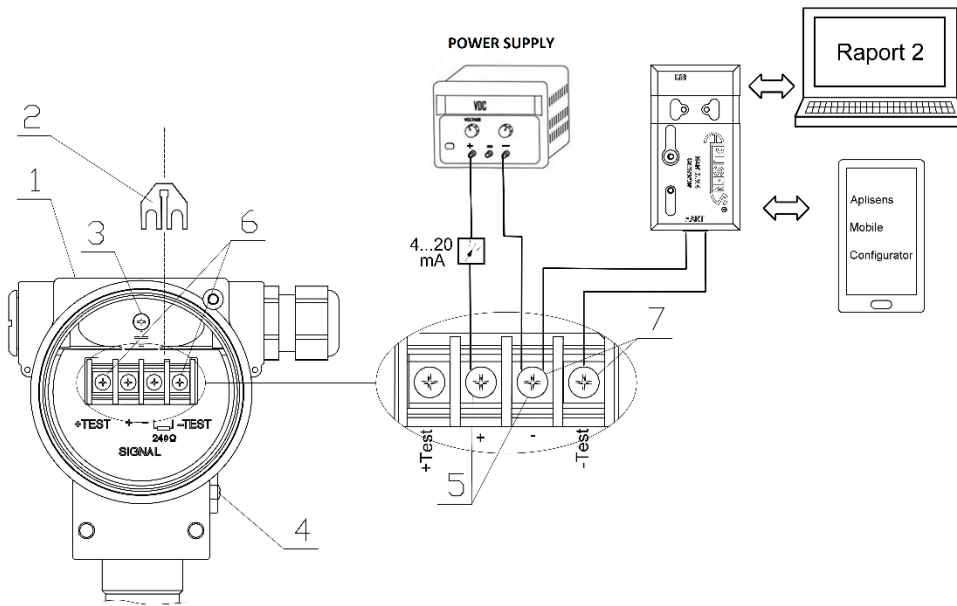

Figure 6. Electrical connection 4 ... 20 mA of HART to APM-2 system in standard version

1. Housing.
2. Removed local HART communication jumper.
3. Internal ground terminal.
4. External ground terminal.
5. Transmitter power terminals, 4 ... 20 mA current loop.
6. Ammeter connection terminals for uninterruptible current measurement (optional).
7. Terminals – point of connection of the communicator or HART modem.

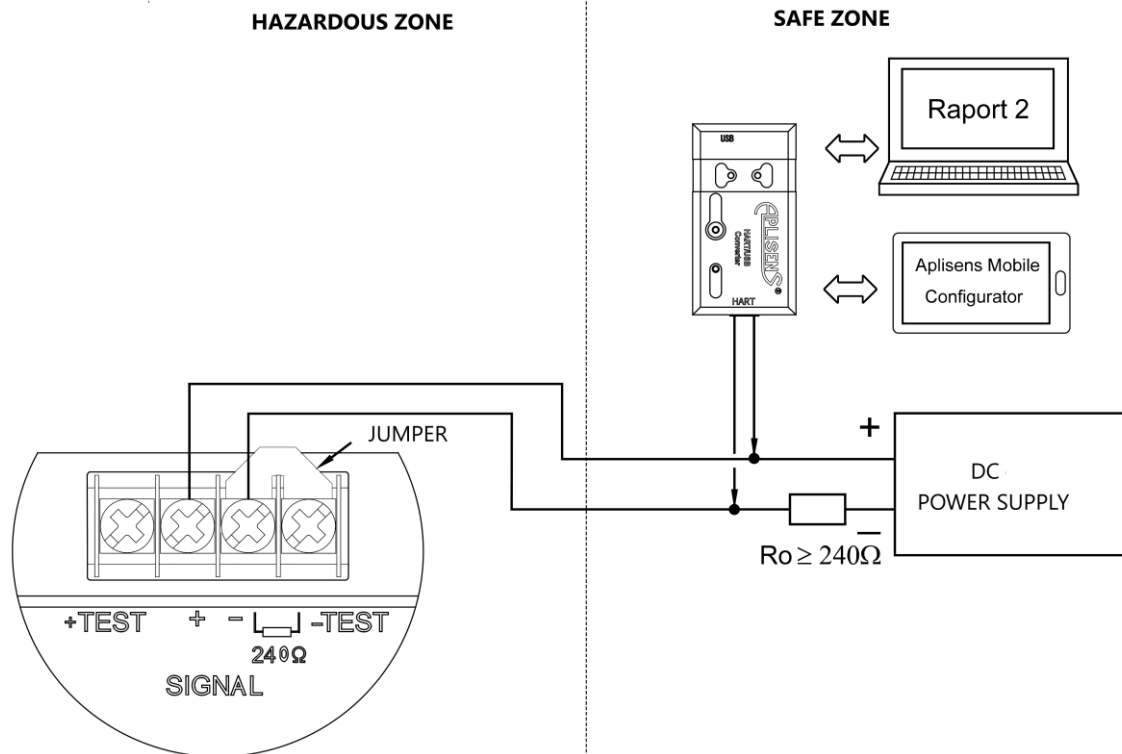

Figure 7. Electrical connection 4 ... 20 mA of HART to APM-2 system in Exd version

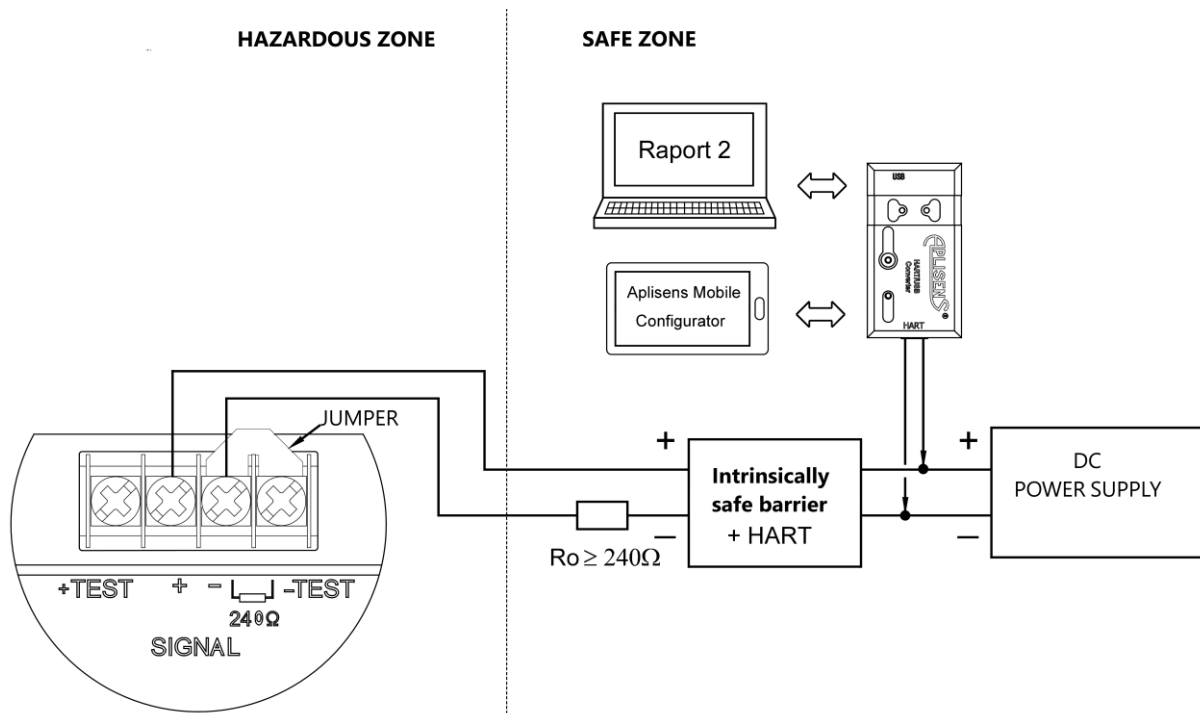

Figure 8. Electrical connection 4 ... 20 mA of HART to APM-2 system in Exi version

It is mandatory to read EN.IX.APM.2 Explosion-proof Device User Manual, containing important information related to the installation of intrinsically safe and flameproof versions of the APM-2 system.

The converter may also be operated using **Aplisens Mobile Configurator** installed on smartphones with Android system and connected using wireless communication.

The software is available on Google Play®:

<https://play.google.com/store/apps/details?id=com.aplisens.mobile.amc>.

7.2. Power supply APM-2 system

7.2.1. Central unit HUB supply voltage



Power cables may be live.
There is a risk of electric shock and/or explosion.



Installation of the APM-2 in explosion-risk atmospheres must comply with national standards and regulations.
All explosion protection data is given in manual PL.IX.APM.2.

Table 3. Permissible APM-2 supply voltages

Version	Minimum supply voltage	Maximum supply voltage
Standard	13 V DC	55 V DC
Exi*		30 V DC
Exd*		36 V DC

* For details on intrinsically safe and flameproof variant see manual PL.IX.APM.2.

7.2.2. Uninterruptible current measurement in 4 ... 20 mA current loop

The central unit HUB is capable of continuous current measurement in the current loop using an ammeter. In order to maintain the current measurement error below 0,05%, the internal resistance of the ammeter shall be less than 10 Ω. Ammeter connection diagram:

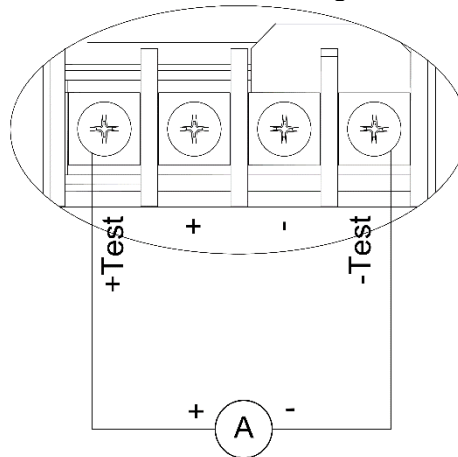

Figure 9. Electrical ammeter connection

7.2.3. Specifications of electrical switching terminals

Internal electrical switching terminals are suitable for conductors with the cross-section from 0,5 to 2,5 mm². The internal and external electrical ground terminal of the body is suitable for conductors with cross-section from 0,5 to 5 mm².

7.2.4. Cabling specification

Aplisens S.A. recommends using two-wire screened twisted pair cable. The outer diameter of the cable shell from 5 to 9 mm is recommended.

7.2.5. Resistance load in power supply line

The power line resistance, power source resistance and other additional serial resistances increase the voltage drops between the power source and the central unit HUB terminals. The maximum HUB current under normal operation conditions is defined as I_max = 20,500 mA + E, where E is the acceptable safety error, which is ± 0,160 mA. The maximum resistance value in the power circuit (along with the power cables resistance) is defined by the formula:

$$R_{L_MAX} [\Omega] \leq \frac{(U - U_{min}) [V]}{0,02066 [A]}$$

where:

U - voltage at the supply terminals of 4 ... 20 mA current loop [V].

U_{min} - minimum supply voltage of APM-2 (→ [Table 3. Permissible APM-2 supply voltages](#)).

R_{L_MAX} - maximum power supply line resistance [Ω].

7.2.6. Shielding

When using a shielded power cable, connect the shield to ground on one side, preferably with the APM-2 system power supply.

7.3. Equipotential bonding

When using an intrinsically safe APM-2 system with an additional overvoltage protection, having the designation “SA version” on the plate, the transmitter should be powered from a galvanically separated power source or, if this is not possible, equipotential bonding of the APM-2 system and the power supply device should be ensured by means of equipotential bonding conductors. In this respect the locally applicable regulations must be observed.

7.4. Overvoltage protection

APM-2 system comply with EMC standards for safety-related products used in general industrial environment. Transmitters in standard and flameproof versions are fitted with overvoltage protection. In intrinsically safe systems, in order to increase the resistance to excessive surge, it is possible to use the overvoltage protection **SA** version. Systems with integrated overvoltage protection **SA** should be grounded.

Overvoltage protection parameters in HUB’s APM-2 system in standard, Exd or Exi SA versions:

- discharge threshold voltage: 230 V DC;
- discharge threshold impulse voltage: 450 V (pulse 100 V/μs);
- discharge threshold impulse voltage: 600 V (pulse 1000 V/μs);
- discharge current for 1 surge: 20 kA, 8/20 μs;
- discharge current for 10 surges: 10 kA, 8/20 μs;
- discharge current for 300 surges: 200 A, 10/1000 μs.

7.5. Final inspection of cabling

After completing the electrical installation of the APM-2 it is necessary to check the following:

- Does the supply voltage measured at the HUB terminals at maximum set current match the range of supply voltage specified on the HUB nameplate?
- Is the APM-2 system connected according to the information given in section → [7.1 Cable connection to central unit HUB](#)?
- Are all the screws tightened?
- Are the APM-2 system covers tightened?
- Whether cable glands, cable connectors and blind plugs are tightened and whether good practices have been followed in guiding cables to glands/connectors to protect against liquid penetration into the modules.
- Whether cable glands, cable connectors and blind plugs are tightened and whether good practices have been followed in guiding cables to glands/connectors to protect against liquid penetration into the modules?

8. START-UP

As standard, the APM-2 is adjusted to a set range equal to the base range, unless a specific set range is provided in the order. The base range and the basic unit of the transmitter can be read out from its nameplate. The type and kind of the process connection can be read out from nameplate of measuring transmitter (→ 5.2 Transmitter identification).



Use the APM-2 system within the allowable pressure limits. Risk of injury due to component breakage after exceeding the maximum permitted operating pressure.

8.1. Alarm configuration

The APM-2 has a complex internal diagnostics, which monitors states of device's circuitry and both process and environmental parameters. Detected hazardous states or malfunctions will force an alarm current $I_{AL} < 3.600 \text{ mA}$. Diagnostics cannot be turned off and alarm current value cannot be modified by user. Figure 10 depicts the transmitter output current operation ranges: normal operation range, saturation range and alarm range.

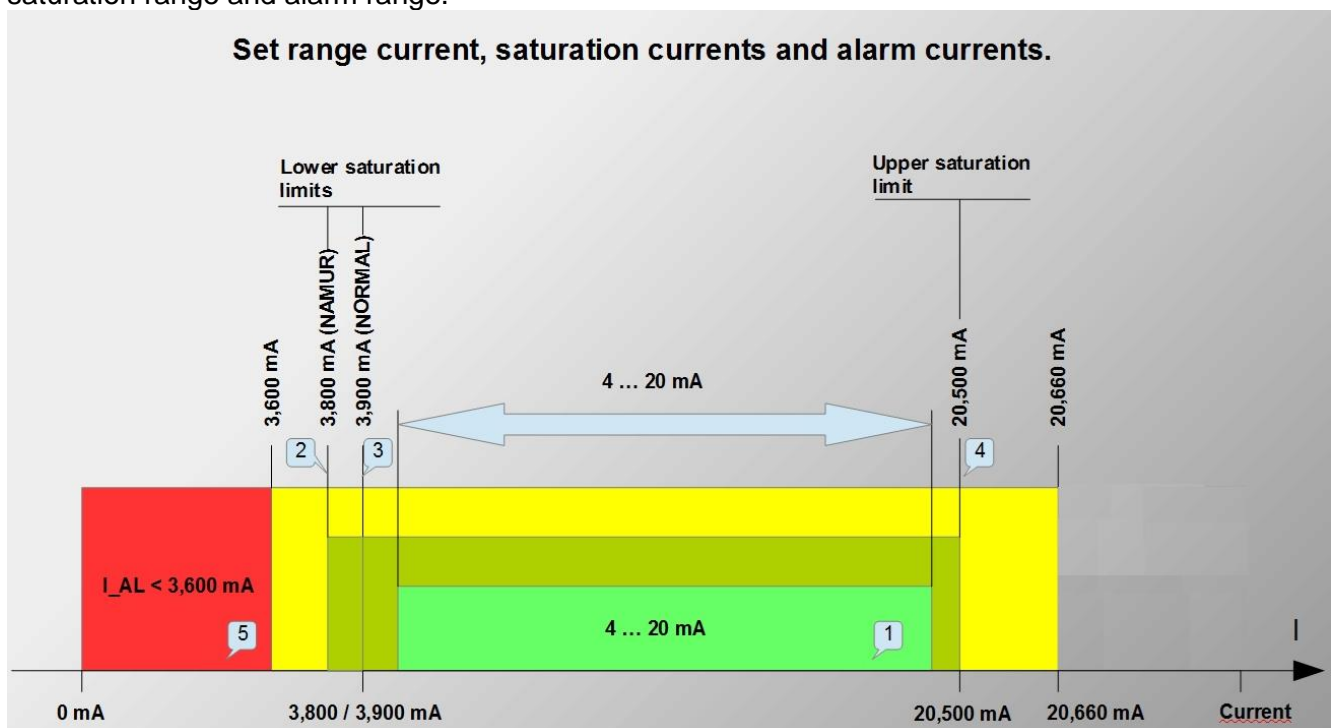

Figure 10. Set range current, saturation currents, alarm currents

1. Set 4 ... 20 mA current area is corresponding to setpoint 0 ... 100% of the process output.
2. Lower saturation current of 3,800 mA for NAMUR mode.
3. Lower saturation current of 3,900 mA for NORMAL mode.
4. Upper saturation current of 20,500 mA for NAMUR and NORMAL mode.
5. Alarm current area $I_{AL} < 3,600 \text{ mA}$ for internal diagnostic alarms.

The APM-2 diagnostics continually tests the environmental parameters:

- Temperature of the pressure measurement structure both pressure sensor.
- CPU structure temperature of both pressure transmitters.
- Temperature of the CPU structure central units. If the transmitter operating temperature limits are exceeded, the diagnostics will trigger an alarm I_{AL} < 3,600 mA. Temperature return to permissible range of the transmitter operation will result in deactivation of the diagnostic alarm mode and return to normal operation.

The APM-2 diagnostics continually tests the pressure process parameters:

- If the pressure/differential pressure value increases above 50% of the base range width from URL point reaching the UPL point, the diagnostics will trigger an alarm I_{AL} < 3,600 mA. The return of the pressure/differential pressure below the UPL point will result in deactivating the alarm and returning the APM-2 to its normal operation.
- If the pressure/differential pressure value decreases below 50% of the base range width from LRL point reaching the LPL point, the diagnostics will trigger an alarm I_{AL} < 3,600 mA. The return of the pressure/differential pressure above the LPL point will result in deactivating the alarm and returning the APM-2 to its normal operation.

The APM-2 diagnostics continually tests electric parameters and software resources of APM-2:

- Any detected non-critical malfunction or error will set a matching system status which may also, depending on device's configuration, force an alarm current I_{AL} < 3.600 mA. Transmitter's alarm state will be kept active until failure is resolved. Error identification number **Exxxx** will appear on LCD2 and **ERROR** message will be displayed on LCD3.
- Any detected critical malfunction or system failure e.g. hardware RAM error, flash memory error, voltage supervisory circuit error, CPU registers error, computation error or internal loop current measurement error – the relative error between process-related current value and measured current value exceeds 1% - will force a device reset, after which full diagnostics scan will be performed.

8.2. Configuration of operating mode

Before starting the work with the APM-2, the following parameters must be configured:

- basic unit of system (HART / Menu: SETUP [●] PV [●] UNIT);
- processing characteristics (HART / Menu: SETUP [●] PV [●] TRANSF);
- the beginning of the set LRV range (HART / Menu: SETUP [●] PV [●] SETLRV);
- the end of the set URV range (HART / Menu: SETUP [●] PV [●] SETURV);
- damping time constant (HART / Menu: SETUP [●] PV [●] DAMPIN);
- NORMAL/NAMUR analogue output operation mode (HART);
- LCD display configuration parameters (HART);
- setting of the settings change lock password (HART)
- assigning the function of high pressure transmitter to the PC1 pressure transmitter (HART / Menu: SETUP [●] ΔP_INV [●] 1H_2L);
- assigning the function of high pressure transmitter to the PC1 pressure transmitter (HART / Menu: SETUP [●] ΔP_INV [●] 1L_2H).

8.3. Correction of impact of transmitter mounting position on site – pressure reset

Once the system is mounted in a target location, in order to eliminate a mounting position influence on differential pressure measurement, the zero trim operation should be executed. In order to do this, when the applied static pressure to both PC1/PC2 sensors is equal, perform zero trim operation using local interface or HART communication.

8.4. Entry of process range by applied process value

Process range can be configured by a local interface or HART communication. The specified range can be set by either range values provided by user or by applied process values. The procedure of setting process range by applied process values is as follows:

- Fill the tank to a level that is desired to be assigned to LRV.
- In MENU operation mode, select „**SETLRV**” function, and then the „**BYMEAS**” option.
- After accepting the applied value as LRV, „**DONE**” message will indicate that applied process value has been saved in device’s memory and transmitter output current will change its value to 4 mA.
- Fill the tank to a level that is desired to be assigned to URV.
- In MENU operation mode, select „**SETURV**” function and then the „**BYMEAS**” option.
- After accepting the applied value as URV, „**DONE**” message will indicate that applied process value has been saved in device’s memory and transmitter output current will change its value to 20 mA.

Once the transmitter configuration has been set, it is required to:

- Secure the device against the possibility of changing the configuration by local interface.
- Set a password, different than a default one „0000”. New password may consist of any combination of four digits 0 ... 9. Password should be stored in a safe place. If the password is lost, its restoration or reset to default value may be performed by specific HART command or by manufacturer.
- Activate the write protect mode, in order to secure the transmitter against accidental, unintentional change of configuration.

Pressure reset can be done via local setpoint change MENU or HART communication. The remaining operations described in this section may only be performed using HART communication.



In the case of the APM-2 Exd system, opening the housing cover in the explosion risk zone in order to use the MENU of local setting changes is prohibited.

8.5. Differential pressure measurements

The base function of APM-2 is differential pressure measurement. APM-2 differential pressure output unit can be configured as one of the many predefined pressure units. User can also provide the custom unit with its desired name and separate range, mapped to process range.

8.6. Level measurements

APM-2 system can be used for liquid level measurement in open or closed tanks. Examples of system installation are shown in (→ [Figure 2. Examples of APM-2 installation on tanks](#)).

The APM-2 can be configured in physical units of liquid column such as water and mercury at several temperatures of the liquid. It is also possible to enter the user’s unit and perform any scaling of the setpoint indication. In case of tanks with irregular shapes, it is possible to use the user’s characteristics to compensate the effect of the shape on the converted volume of liquid in the tank.

8.7. Flow measurements

Differential pressure transmitter APM-2 can be used for venturi flow measurements. Flow measurements often require setting of pressure-processing characteristics for output current setpoints other than linear. In APM-2 the following characteristics are available for the user:

- linear characteristics;
- square root function with 0.2% of process range hysteresis around cut-off point of dead band;
- cubic root function with 0.2% of process range hysteresis around cut-off point of dead band;
- fifth root function with 0.2% of process range hysteresis around cut off point of dead band;
- special: piecewise linear function, based on multipoint user-defined array;
- square characteristics;
- relay function with state transition around cut off point;
- manufacturer_1: spline of two linear functions followed by square root function. Center of second linear function is set by cut-off point value, with function range between 0.2% of process range;
- manufacturer_2: square root function with initial linear region and 0.2% of process range hysteresis around cut off point between regions.

Dead band is described as a region between 0% of process range and cut off point of its characteristic. By default, the cut-off point value is set to 0.8% of process range and can be modified by user in range between 0.25-100%.

9. OPERATION

The APM-2 system gives the possibility of rotating the housing and adjusting the display position to the mounting position of the body. To rotate the housing, loosen the screw (item 1), position the central unit HUB housing (item 2) as required, tighten the screw (item 1). Access to the extensions (item 4) used to rotate the display is provided after opening the front cover (item 3).

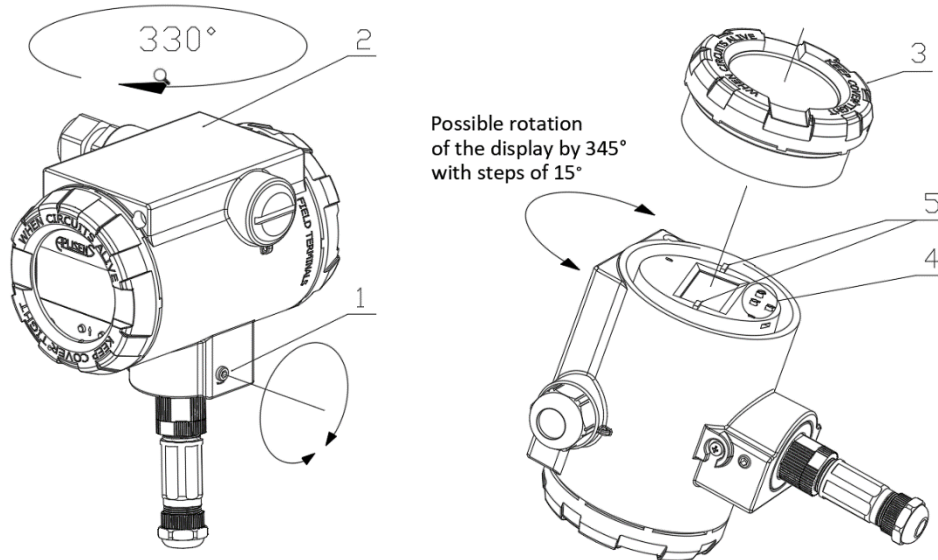

Figure 11. Rotation of the housing, change of display position and access to buttons

1. Screw.
2. Housing.
3. Front cover.
4. Buttons.
5. Extensions for display rotation.



In hazardous zone, do not unscrew the housing covers after connecting the Exd flame-proof central unit to the power source.

9.1. LCD display

The LCD has three primary information fields identified in the figure below as LCD1, LCD2, LCD3.

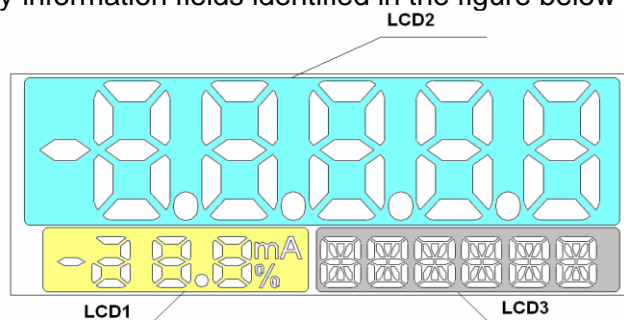

Figure 12. Display information fields

LCD1 field:

[mA] - value (milliamperes) of process current in line 4 ... 20 mA, proportional to the measured pressure.

[%] - value (percentage) of the setpoint $U(t)$ of current controller in current loop 4 ... 20 mA. This value is the ratio of the process current $I_p(t)$ to the current range width according to the following formula:

$$\%U(t) = \frac{I_p(t) - 4 \text{ [mA]}}{16 \text{ [mA]}} \cdot 100 \text{ [%]}$$

LCD2 field:

The LCD2 field is used mainly to display floating point decimal values in a unit displayed on LCD3. In some cases, other messages may be displayed:

- ● ● ● ● or - ● ● ● ●, when displayed variable value exceeds displayed range, defined by a comma (point) position;
- **Exxxx**, where xxxx is an error identification number, when error that forces an alarm current is detected by transmitter diagnostics;
- **U_AL**, when at least one of process variables' value exceeds the user-defined alarm range;
- **NAN**, when displayed value is defined as „Not a Number” in IEEE-754 standard;
- **IdXXX**, where XXX is a decimal number of currently displayed value of enumerated system parameter;
- **INFO**, when [●] is required to be pressed, in order to obtain additional information about operating parameters.

LCD3 field:

Name of unit assigned to displayed variable;

- **ERROR** when error that forces an alarm current is detected by transmitter diagnostics;
- **PC1, PC2, HUB** - as a name of information source of displayed variable;
- **Zxxxxx** - where xxxxx is current zero trim value of primary variable, in unit assigned to primary variable;
- **Lxxxxx** - where xxxxx is current lower range value of primary variable, in unit assigned to primary variable;
- **Uxxxxx** - where xxxxx is current upper range value of primary variable, in unit assigned to primary variable;
- **Dxxxxx** - where xxxxx is current damping factor of primary variable, in seconds;
- Name of currently selected current output transfer function;
- **%xxxxx** - where xxxxx is current value of cut-off point of current output transfer function;
- **%-----**, when currently selected current output transfer function does not use a cut-off point in its characteristics;
- **DONE** when function selected by local interface was correctly executed;
- **LOCKED** when local interface operation mode is being changed to MENU mode while the MENU mode access lock is active;
- **ER_Lxx** where xx is error code, when option selected by local interface could not have been finished correctly;
- **WG_Lxx** where xx is a warning code, when option selected by local interface was correctly executed, but value of modified parameter reached the parameter operation limit.

Abbreviations of physical units of pressures and levels and their description:

INH2O2	Inches of water column with temperature of 20°C.	MMH2O4	Millimeters of water column with temperature of 4°C (39,2°F).
INHG	Inches of mercury column with temperature of 0°C.	INH206	Inches of water column with temperature of 15.6°C (60°F).
FTH2O2	Feet of water column with temperature of 20°C (68°F).	CMH204	Centimeter of water column with temperature of 4°C (39,2°F).
MMH2O2	Millimeters of water column with temperature of 20°C (68°F).	CMHG	Centimeters of mercury column with temperature of 0°C (32°F).
MMHG	Millimeters of mercury column with temperature of 20°C.	LBSQFT	Pound per square foot.
PSI	Pounds per square inch.	HPA	Hectopascal.
BAR	Bars.	PSIA	Pound per square inch taking into account atmospheric pressure.
MBAR	Millibars.	KGSQM	Kilograms per square centimeter.
GSQCM	Grams per square centimeter.	FTH204	Foot of water column with temperature of 4°C (39,2°F).
KGSQCM	Kilograms per square centimeter.	FTH206	Foot of water column with temperature of 15.6°C (60°F).
PA	Pascals.	MHG	Meters of mercury column with temperature 0°C (32°F).
KPA	Kilopascals.	MPSI	Megafunt per square inch.
TORR	Torr.		
ATM	Atmosphere.		
MH2O4	Metres of water column with temperature of 4°C		
MPA	Megapaskale.		
INH2O4	Inches of water column with temperature of 4°C.		

Available temperature units:

- Celsius degrees °C,
- Fahrenheit degrees °F,
- Rankine degrees °R,
- Kelwiny K.

Available variables displayed:

ΔPRESS	Differential pressure.
PRESS	Static pressure of the transmitter PC1/PC2.
TEMP	Temperature of the microcontroller HUB.
CPU_T	Temperature of the microcontroller PC1/PC2.
SENS_T	Temperature of the transmitter measuring sensor PC1/PC2.
USER	User unit.

Abbreviations displayed during configuration via local MENU and their descriptions:

:-BACK	Return to previous MENU list.
:-EXIT	Exit MENU mode of local interface.
LCD2VR	Option of setting the displayed variable.
HUB	Option of selecting Central Unit process variables and User's Unit.
ΔPRESS	Differential pressure device variable (Id 0).
TEMP	Central Unit's temperature device variable (Id 7).
USER	User's Unit and scaling (Id 240).
PC1	Option of selecting PC1-related process variables.
PC2	Option of selecting PC2-related process variables.
PRESS	Static pressure of PC1/2 device variable (Id 1/2).
SENS_T	Temperature of PC1/2 sensing element device variable (Id 3/4).
CPU_T	Temperature of PC1/2 processor device variable (Id 5/6).
DV_ID	Option of displaying the assignment of displayed variables' Id number to LCD3 name.
PC1_P	PC1 static pressure device variable (Id 1).
PC2_P	PC2 static pressure device variable (Id 2).
PC1_ST	PC1 sensing element temperature device variable (Id 3).
PC2_ST	PC2 sensing element temperature device variable (Id 4).
PC1_CT	PC1 processor temperature device variable (Id 5).
PC2_CT	PC2 processor temperature device variable (Id 6).
HUB_T	Central Unit's temperature device variable (Id 7).
LCD1VR	Option of setting the type of measurement displayed on LCD1.
PERCEN	Option of selecting the display of percent of range on LCD1.
CURREN	Option of selecting the display of transmitter output current on LCD1.
LCD2DP	Option of setting the position of comma/decimal point.
X.XXXX	Option of selecting the position of comma/decimal point.
XX.XXX	Option of selecting the position of comma/decimal point.
XXX.XX	Option of selecting the position of comma/decimal point.
XXXX.X	Option of selecting the position of comma/decimal point.
XXXXX.	Option of selecting the position of comma/decimal point.
CTRAST	Option of setting the LCD contrast.
CONT_0	Option of selecting the LCD contrast.
CONT_1	Option of selecting the LCD contrast.
CONT_2	Option of selecting the LCD contrast.
CONT_3	Option of selecting the LCD contrast.
CONT_4	Option of selecting the LCD contrast.
CONT_5	Option of selecting the LCD contrast.
SETUP	MENU list of configurable parameters of APM-2.
PV	MENU list of primary variable configuration options.
BYMEAS	Option of setting the primary variable parameter value by measured value (PVZERO, SETLRV, SETURV).
BYVAL	Option of setting the parameter value by entered value (SETLRV, SETURV, DPIONT, USRLRV, USRURV).
RECALL	Option of restoring APM-2 configuration parameters value to the factory settings.
SETLRV	Option of setting the LRV (Lower Range Value of process range of primary variable).
SETURV	Option of setting the URV (Upper Range Value of process range of primary variable).
UNIT	Option of setting the unit of primary variable.
DAMPIN	Option of setting the damping time constant of primary variable.
0 s	Option of selecting the damping time constant.
2 s	Option of selecting the damping time constant.

5 s	Option of selecting the damping time constant.
10 s	Option of selecting the damping time constant.
30 s	Option of selecting the damping time constant.
60 s	Option of selecting the damping time constant.
TRANSF	Option of setting the transmitter current output transfer function.
LINEAR	Option of selecting a linear function as transfer function.
SQRT	Option of selecting a square root function as transfer function.
SQRT^3	Option of selecting a cubic root function as transfer function.
SQRT^5	Option of selecting a fifth root function as transfer function.
SPECIA	Option of selecting a special function as transfer function.
SQUARE	Option of selecting a square function as transfer function.
DISCRT	Option of selecting a relay function as transfer function.
SQRT_1	Option of selecting a manufacturer_1 function as transfer function.
SQRT_2	Option of selecting a manufacturer_2 function as transfer function.
DPOINT	Option of setting the transfer function cut off point value.
0.0%	Option of selecting the cut-off point value.
0.4%	Option of selecting the cut-off point value.
0.6%	Option of selecting the cut-off point value.
0.8%	Option of selecting the cut-off point value.
1.0%	Option of selecting the cut-off point value.
1.2%	Option of selecting the cut-off point value.
HUB	MENU list of Central Unit's configurable parameters.
USER	MENU list of User Unit configuration.
USRLRV	Option of setting the LRV point of User Unit.
USURV	Option of setting the URV point of User Unit.
PCSAVE	Option of assigning the connected sensors to Central Unit. If connected sensors are already
ΔP_INV	Option of setting the differential pressure device variable calculation method.
1H_2L	Option of selecting the differential pressure device variable calculation method.
1L_2H	Option of selecting the differential pressure device variable calculation method.
FACTOR	Option of restoring APM-2 configuration parameters values to the factory settings.
RECALL	Option of transmitter software restart.
RESET	Option of setting the differential pressure device variable calculation method.
CANCEL	Return to SETUP MENU list from software restart option.
ACCEPT	Transmitter software restart confirmation.
SVC_MOD	Option of toggling the service operation mode of transmitter.
SVC_ON	Option of enabling the service operation mode of transmitter.
SVCOFF	Option of disabling the service operation mode of transmitter.
INFO	MENU list of operating parameters of device.
PV_IDX	Option of displaying currently assigned process variable to primary variable.
DV_CNT	Option of displaying the number of transmitter device variables.
HW_VER	Option of displaying the Central Unit's hardware version number.
SW_VER	Option of displaying the Central Unit's firmware version number.
HT_VER	Option of displaying the implemented HART protocol version number.
RUNTIM	Option of displaying the operating time of transmitter.
DAYS	Option of displaying the number of full days of operating time of transmitter.
HOURS	Option of displaying the number of full hours of operating time of transmitter.
MINS	Option of displaying the number of full minutes of operating time of transmitter.
SECS	Option of displaying the number of full seconds of operating time of transmitter.
P_UTL	Option of displaying the upper transmitter limit of pressure device variable of PC1/2.
P_LTL	Option of displaying the lower transmitter limit of pressure device variable of PC1/2.
T_UTL	Option of displaying the upper transmitter limit of temperature device variable of PC1/2.
T_LTL	Option of displaying the lower transmitter limit of temperature device variable of PC1/2.
ACQ_%	Option of displaying the ratio between correct data read operations and all read operations from.
1_HOUR	PC1/2 sensor in %.

Abbreviations assigned to displayed name of primary variable in HELP mode:

ΔPRESS	Differential pressure device variable.
HUB_T	Central Unit temperature device variable.
PC1_P	PC1 static pressure device variable.
PC1_CT	PC1 processor temperature device variable.
PC1_ST	PC1 sensing element temperature device variable.
PC2_P	PC2 static pressure device variable.
PC2_CT	PC2 processor temperature device variable.
PC2_ST	PC2 sensing element temperature device variable.

9.2. Abbreviations of error codes of local interface configuration options and their descriptions:

All presented error codes are displayed on LCD3 field.

It is displayed if:

ER_L06	<ul style="list-style-type: none"> An unexpected internal error occurred which aborts execution of selected option. An option of setting the LRV/URV of process range by measured value was selected when PC1/2 sensors were not assigned to Central Unit.
ER_L07	An option that modifies the parameter, which value is stored in non-volatile memory, was selected, when write protect mode is active.
ER_L09	Parameter value obtained by selected option is greater than upper limit of modified parameter range.
ER_L10	Parameter value obtained by selected option is less than lower limit of modified parameter range.
ER_L14	Value of URV obtained by selected function cannot be applied, because it reduces the process span below allowable limit.
ER_L29	During PC1/2 Assignment option execution (PCSAVE) an internal error occurred, aborting the execution. Pressing the [●] button will restart the device.
WG_L06	PC1/2 sensors assignment option was selected when connected sensors are already assigned to Central Unit. All device variables' range values were restored to LRL and URL values of device variables.
WG_L14	Value of LRV obtained by selected function reduces the previously set process range. Acceptance of obtained value will push the URV value to one of base limits (URL, LRL).

ASCII characters displayed on LCD3 in user's unit:

Using HART communication, the user can configure its own 6-character unit displayed on LCD3. It is possible to display ASCII characters from the range (32 ... 96 dec) or (20 ... 60 hex), i.e.:

!"#\$%&'()*+,-./0123456789:;<=>?@ABCDEFGHIJKLMN OPQRSTUVWXYZ[\]^_`

9.3. Local buttons

To control the local interface, use the:

- [●] action button;
- [↑] move up button;
- [↓] move down button.

9.4. Local configuration of setpoints

APM-2 allows you to perform local configuration of some of the most commonly used settings with the power of local buttons and a local LCD display.

9.5. Navigation in local setpoints MENU

In order to gain an access to MENU mode of local interface, press and hold [●] button for at least 3 seconds. Menu mode is active when the LCD3 field displays „:-EXIT“. By pressing [↑], [↓] buttons, user can navigate through local options of MENU. Holding any of those two buttons will result in MENU option's roll.

9.6. Acceptance of local setpoints

Button [●] is configured to execute MENU mode options, selected by user. Acceptance of modified parameter's value is confirmed by device, by displaying „DONE” on LCD3 field. When parameter's value modification process is finished, the state of local interface of transmitter returns to selected option's corresponding „:-BACK” field. When in MENU mode, if no button is pushed during period of 2 minutes, the device will automatically return to measurement mode of local interface. MENU mode can also be quit by holding [●] for 3 seconds, when „:-EXIT” is being displayed on LCD3 field.

9.7. Structure of local setpoints MENU

Press and hold the action button [●] for 3 seconds. When moving in the area of the active local MENU, there are two lengths of holding the button - short or long press. Continuous pressing of the [↑] or [↓] buttons results in the scrolling of the MENU items. If the local MENU remains inactive for a time greater than 2 minutes, after this time the transmitter will automatically exit the MENU mode and switch to displaying the process variable.

Measurement Mode:

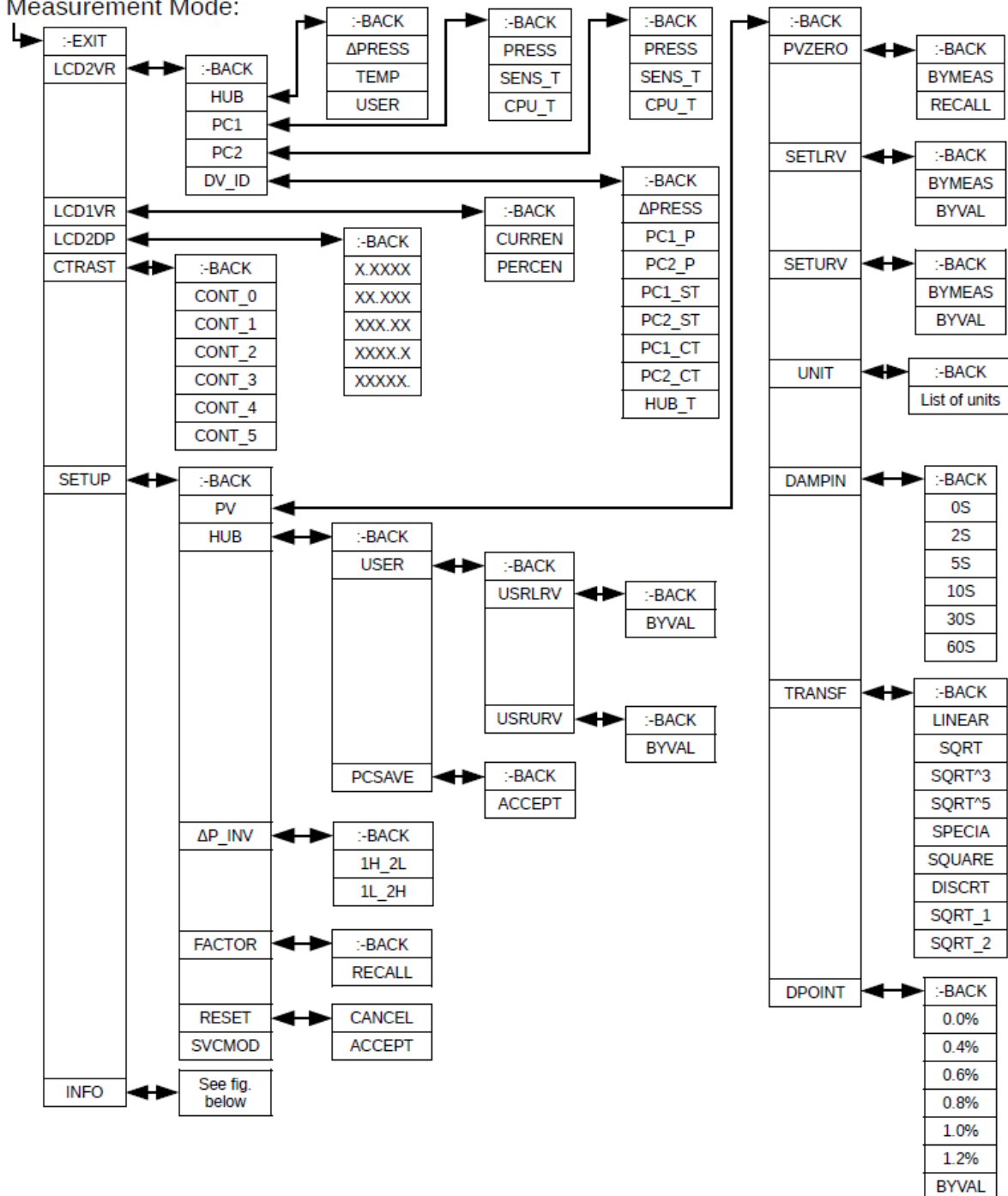

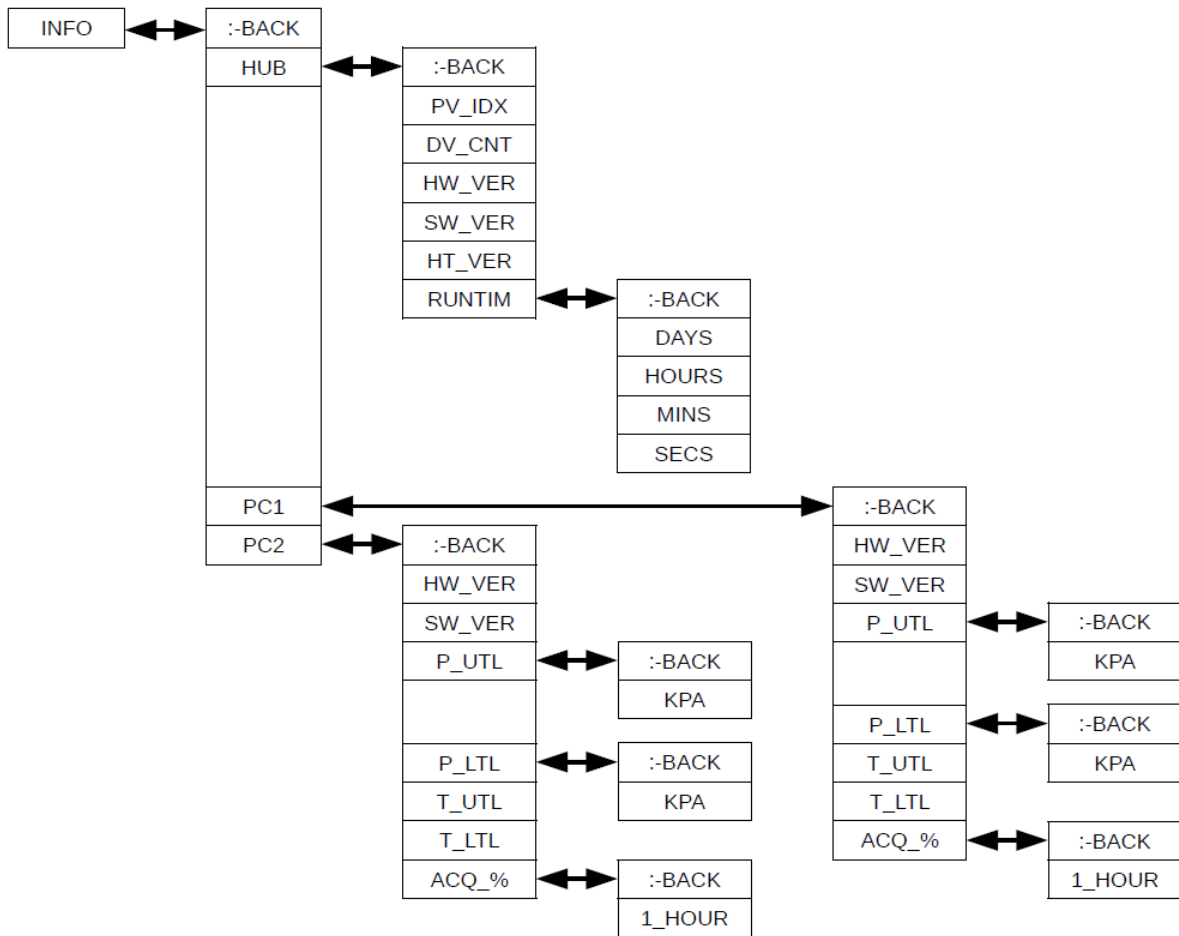

9.8. HELP mode structure

In measurement mode of local interface, user can rapidly display the values of selected primary variable parameters, or displayed variable assignment. Mentioned parameters can be shown on LCD3 field by pressing [↑], [↓] buttons. By this action, local interface enters the HELP mode (without entering MENU mode).

Table 4. APM-2 HELP mode structure

LCD2VR-DV_ID	[↑]	Name of process variable currently assigned to displayed variable.
LCD2VR-Source	[↑]	Name of device that provides information about displayed variable.
LCD2VR-Unit	-	Default local interface setting in measurement mode, displaying the unit of displayed variable.
PV-Name	[↓]	Name of process variable assigned to primary variable
PV-Zero	[↓]	Zero trim value of primary variable, displayed as „Zxxxxx” in unit of primary variable.
PV-LRV	[↓]	Lower Range Value of primary variable, displayed as „Lxxxxx” in unit of primary variable.
PV-URV	[↓]	Upper Range Value of primary variable, displayed as „Uxxxxx” in unit of primary variable.
PV-Damping	[↓]	Value of time constant damping, displayed as „Dxxxxx” in seconds.
PV-Transf	[↓]	Value of time constant damping, displayed as „Dxxxxx” in seconds.
PV-DPoint	[↓]	Cutoff point value of transfer function, displayed as „%xxxxx”. If transfer function does not support a dead band, „%-----” is displayed instead.

9.9. Remote configuration of setpoints (HART)

The APM-2 allows to read out and configure the parameters via HART 7 communication using 4 ... 20 mA loop as a physical layer for FSK BELL 202 modulation.

9.9.1. Compatible devices

The following devices may be used to communicate with the APM-2:

- PC computers equipped with HART modem (e.g. HART/USB converter by Aplisens S.A.) with Windows7 or Windows10 operating system with installed Raport 2;
- PC computers equipped with HART modem using software from other companies, accepting DDL and DTM libraries;
- smartphones with Android system, using a converter providing wireless communication (e.g. HART/USB converter by Aplisens S.A.) using Aplisens Mobile Configurator. The software is available on Google Play under the link:

<https://play.google.com/store/apps/details?id=com.aplisens.mobile.amc>.

9.9.2. Compatible configuration software

- Raport 2 Aplisens under control of Windows 7 or Windows 10;
- Aplisens Mobile Configurator under control of the Android system;
- every software from other companies accepting DDL and DTM libraries.

9.9.3. Local HART communication jumper

The APM-2 allows to use the local HART communication. To do this you can use a HART communicator unit or modem interoperating with a computer or a smartphone.

In order to establish communication, it is necessary to:

- remove the HART communication jumper (→ [Figure 6. Electrical connection 4 ... 20 mA of HART to APM-2 system in standard version](#));
- connect the modem to electrical terminals (→ [7.1.2 Connection of pressure transmitters PC1 and PC2 to the communication connector of the HUB central unit](#)).

10. MAINTENANCE

10.1. Periodic inspections

Periodic inspections shall be carried out in accordance with applicable standards. During the inspection, the condition of the pressure (absence of loosened elements and leaks) and electrical (check of connections reliability and condition of gaskets and glands) connectors, condition of separating diaphragms (tarnish, corrosion) and stability of fixing of the housing and mounting bracket (if used) shall be checked. Check the processing characteristics by performing the operations specific for the CONFIGURATION procedure.

10.2. Non-periodic inspections

If the APM-2 system at the installation site has been exposed to mechanical damage, pressure overload, hydraulic pulses, overvoltage, deposits, medium crystallization, undercutting of the diaphragm, or incorrect operation of the APM-2 is detected, the device should be inspected. Check the condition of the diaphragm, clean it, check the electrical functionality of the transmitter and the processing characteristics.



If there is no signal in the transmission line or its value is improper, check the supply line, connection status on terminal blocks, connectors, etc. Check if the supply voltage and load resistance are correct.

10.3. Cleaning/washing

To remove impurities from the external surfaces of the APM-2 system wipe it with a cloth dampened in water.

10.3.1. Diaphragm cleaning

The only possible method of cleaning the transmitter diaphragms is to dissolve the sludge produced.



Do not remove deposits and impurities from the transmitter diaphragms, which are formed during operation, mechanically using tools, since the diaphragms and the transmitter can be damaged.

10.4. Spare parts

For APM-2 system spare parts that may wear out or possibly replace, please contact the manufacturer.

10.5. Repair

Faulty or non-operational transmitter/central unit shall be provided to the manufacturer.

10.6. Returns

In the following cases the transmitter should be returned directly to the manufacturer:

- need for repair;
- need for factory calibration;
- replacement of improperly selected/shipped transmitter.

11. SCRAPPING, DISPOSAL



Worn or damaged devices shall be scrapped in accordance with WEEE Directive (2012/19/EU) on waste electrical and electronic equipment or returned to the manufacturer.

12. HISTORY OF REVISIONS

Revision No.	Document revision	Description of changes
-	01.A.001/2021.10	Initial document version. Prepared by DBFD, DKE1, DR.
1	01.A.002/2022.06	QR codes were updated according to the new software version.
2	01.A.003/2024.01	Adding information about changing the assignment of the function of high pressure transducer. Editorial changes.

