

IO.ALA-01
Edycja 01.A.001/05.17





INSTRUCTION MANUAL

Fuel tank theft alarm

ALA-01

APLISENS S.A., 03-192 Warszawa, ul. Morelowa
tel. +48 22 814 07 77; fax +48 22 814 07 78
, e-mail:

Symbols used

Symbol	Description
	Follow the instructions from this document carefully to ensure safety and full functionality of the device.
	Information particularly useful for the installation and use of the device.
	Information particularly useful for the installation and use of the device by Ex.
	Information on the disposal of used equipment.

BASIC REQUIREMENTS AND SAFETY OF USE



- The producer takes no liability for damage resulting from incorrect installation of the device, neglecting to keep the device in proper technical, and using the device for purposed other than its intended purpose.
- Installation should be conducted by qualified personnel, authorized for installation of electrical equipment and measuring devices. The installer ins responsible to conduct the installation according to this manual as well as laws and standards of safety and electromagnetic compatibility applicable for this kind of installation.
- In any installation equipped with measuring devices, there is an injury hazard from compressed agent in case of a leak. Follow all safety requirements during the installation, use, and inspection of the display.
- In case of malfunction, disconnect the device and return it to the producer or an authorized service unit for repair.



- In order to minimize the possibility of malfunction and the resulting hazard to personnel, avoid installing the device in dangerous environment where there is a possibility of the following:
- mechanical impact, excess shock and vibration.
 - Excess temperature fluctuation.
 - Steam condensation, dusting, icing.



Installation of intrinsically safe devices must be conducted very carefully, following all standards and laws applicable for installations of this kind.

Changes and alterations introduced in production documents may anticipate the update of user's paper documents. Up-to-date instruction manuals are available on producer's website at www.aplisens.pl

CONTENTS

1.WSTĘP	4
2.BEZPIECZEŃSTWO	4
3.LISTA KOMPLETNOŚCI	4
4.TRANSPORT I PRZECHOWYWANIE	5
4.1.Transport	5
4.2.Przechowywanie	5
5.GWARANCJA	5
6.BUDOWA	5
6.1.Przeznaczenie i cechy	5
6.2.Budowa i gabaryty	5
7.MONTAŻ	6
8.PODŁĄCZENIE	7
9.KONFIGURACJA	8
9.1.Podłączenie alarmu do konwertera USB/RS-485	8
9.2.Konfiguracja alarmu	10
9.3.Obługa protokołu MODBUS RTU	15
9.4.Wykaz rejestrów	18
10.PARAMETRY TECHNICZNE	19
10.1.Parametry elektryczne	19
10.2.Dopuszczalne parametry otoczenia i pracy	19
10.2.1.Odporność mechaniczna	19
10.2.2.Rezystancja izolacji	19
10.2.3.Wytrzymałość izolacji	20
10.2.4.Stopień ochrony obudowy	20
10.3.Budowa	20
10.3.1.Obudowa	20
10.3.2.Materiał kabla	20
11.PRZEGLĄDY	21
11.1.Przeglądy okresowe	21
11.2.Przeglądy pozaokresowe	21
12.ZŁOMOWANIE, UTYLIZACJA	21
13.INFORMACJE DODATKOWE	21

1. INTRODUCTION

The subject of this instruction manual is ALA-01 fuel tank theft alarm with an option to program basic sensor parameters.

The manual includes data, hints, and recommended action for installation and usage of the alarm, as well as troubleshooting tips.

2. SAFETY



- Read this instruction carefully prior to, installation, startup, or any other work.
- Installation and maintenance can only be conducted by qualified personnel, authorized to install electrical equipments and measuring devices.
- Use the alarm according to its intended use, without exceeding maximum acceptable parameters.
- Prior to assembly or disassembly of the alarm, be sure to disconnect the power source.
- It is not acceptable to conduct any repair or otherwise tamper with the electronic circuit of the alarm. Damage assessment and possible repair can only be made by the producer or an authorized unit.
- Do not use the device when it is damaged. If malfunction occurs, disconnect the device.

1. SET LIST

Along with the alarm, the user receives the following:

- a) Product certificate, functioning as a warranty card;
- b) Declaration of conformity (on customer's request);
- c) Instruction Manual designated „IO.ALA-01”

Positions b), c) are available from the website www.aplisens.pl

1. TRANSPORT AND STORAGE

1.1. Transport

When transported, the alarms should be packed in individual and/or group packaging and carried on a covered means of transport. The packaging should be secured against shifting and atmospheric weather effects.

1.2. Storage

The alarm should be stored in the manufacturer's packaging, in a covered room, free of vapor and corrosive agents, where temperature and relative humidity do not exceed maximum acceptable limits.

2. WARRANTY

The producer provides warranty under the conditions specified in Product Certificate, functioning as a warranty card.

Warranty will be void if the device is not used according to its intended use, the user does not follow this instruction manual, the device is handled by unqualified personnel or the alarm has been tampered with.

3. STRUCTURE

3.1. Intended use and features

The alarm is a device that secures the fuel tank against mechanical damage and fuel theft when the vehicle is parked. All attempts of unauthorized access to the tank are detected by the device's electronic system and immediately relayed to the external decision circuit. The circuit verifies the event and responds in various ways, e.g. triggers a local sound and light alarm (panic function), turns on the lights on the protected vehicle, sends a notification signal via wireless GSM system. The device is equipped to operate outdoors.

3.2. Structure and dimensions

ALA-01 type alarm is equipped with micro-processing electronic circuit and a set of sensors placed in a closed and sealed housing, additionally sealed with air-tight compound. Triggering the sensors, according to the programmed settings, will trigger the alarm by activating binary outputs or read from RS-485 digital output.

RS-485 digital communication output is used for configuring the alarm. The ready status of the alarm is activated with a switch located in driver's cabin or RS-485 digital output.

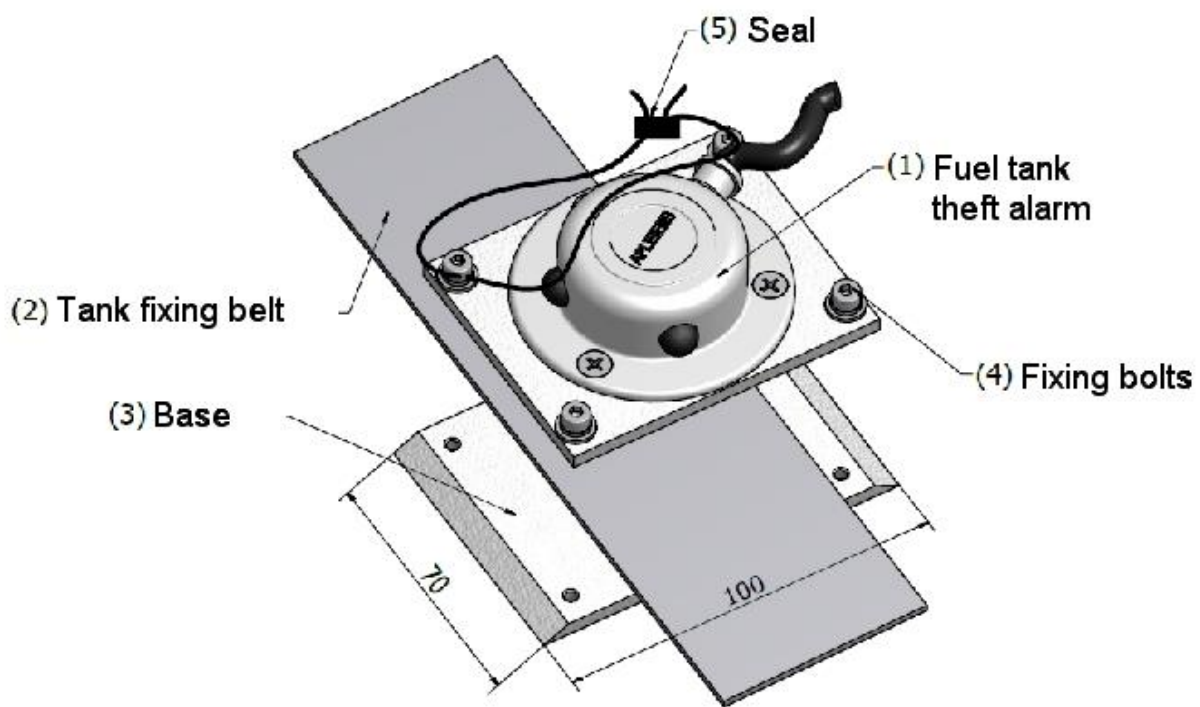

Pic. 1. ALA-01 alarm, dimensions

4. INSTALLATION

ALA-01 alarm should be installed immediately on the fuel tank fixing belt (non-invasive installation) in such a way, so that the range of movement sensors covers the entire front plane of the tank.

Installation on the fuel tank fixing belt must be conducted according to pic. 1 and pic. 2.

Installation of alarm on tank belt - steps:

1. Loosen the tank fixing belt (2).
2. Slide the base under the belt (3).
3. Put the alarm (1) on the fixing belt (2).
4. Screw the four fixing bolts (4).
5. Secure the alarm by threading the seal line (5) through two fixing bolts (4).

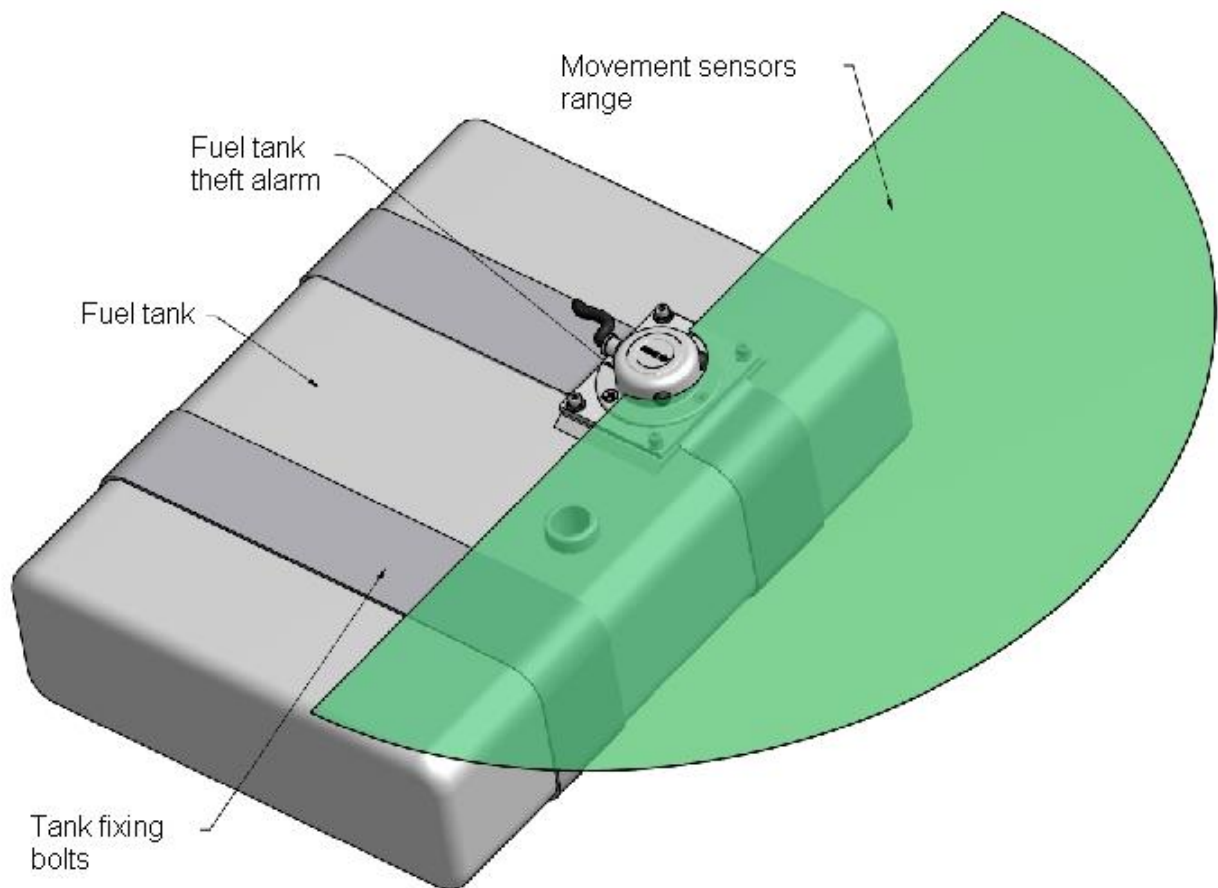

Pic. 2. ALA-01 installation on a tank

1. CONNECTION

All connection and installation steps must be taken with the power source disconnected.

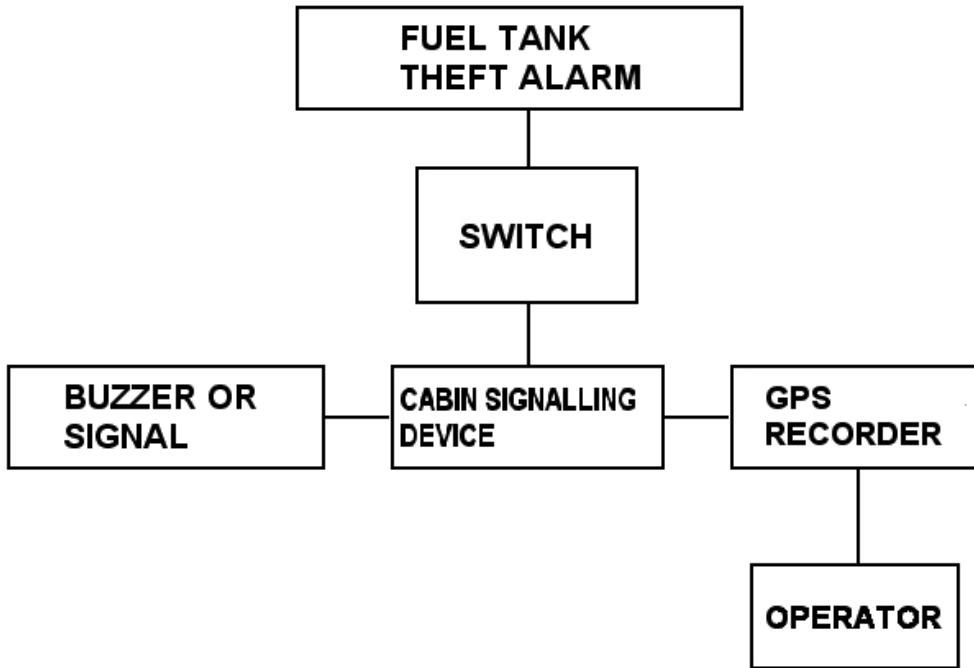

Pic. 3. Connecting ALA-01 to the system - block diagram.

The signal wires in **ALA-01** must be connected according to the following table.



Keep the polarity of the connection according to the following table.

Table 1. Cable wire markings

Function	Polarization	Wire color
Power	+	Red
	-	Blue/Screen
Two-state output 1	+	Grey
Two-state output 2	+	Black
RS-485	+	Yellow
	-	Green

2. CONFIGURATION

2.1. Connecting the alarm to the USB/RS-485 converter

In order to complete the configuration of the device, it is necessary to connect the alarm to a computer with configuration software through the USB/RS-485 converter. The picture below shows how to do it.

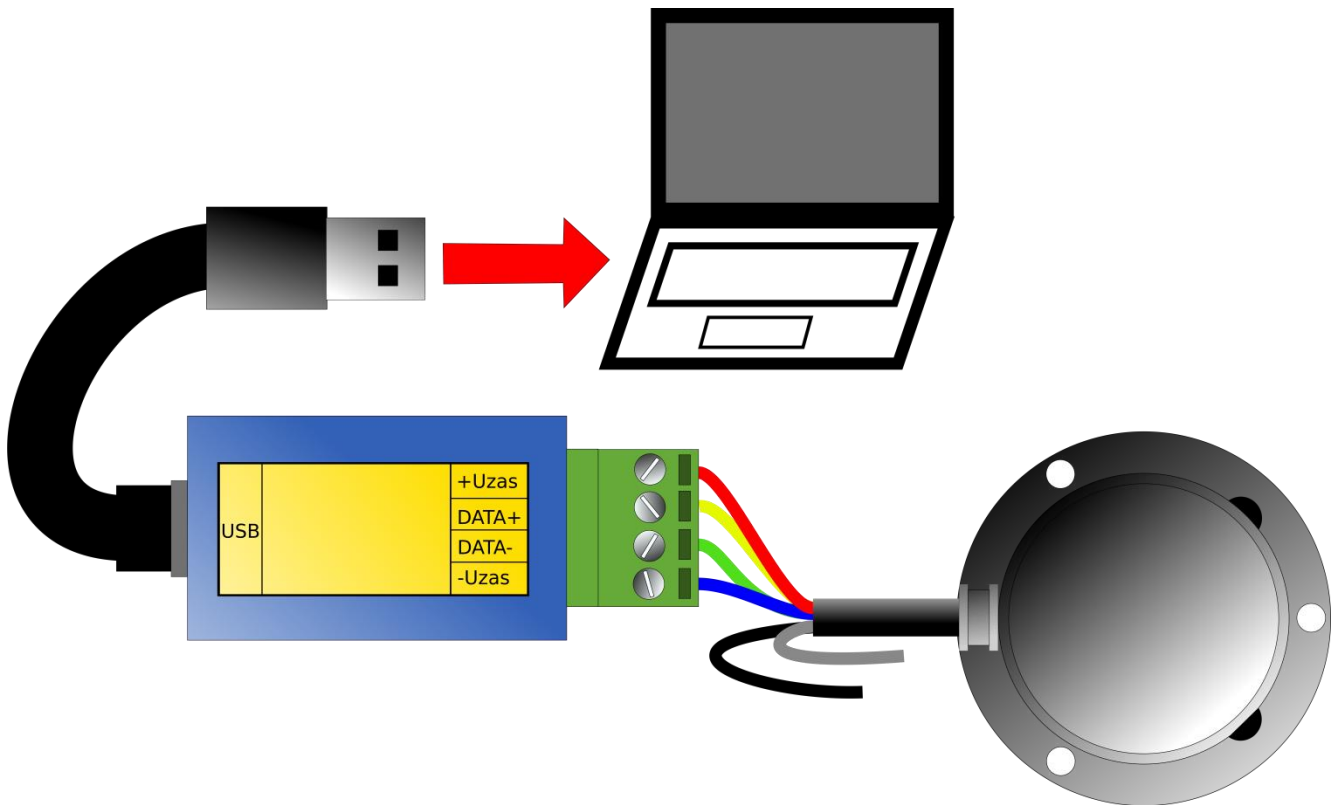

2.2. Alarm configuration

User can change the setting and reading of alarm register with configuration software and RS-485 output with MODBUS RTU protocol. Use the USB/RS485 converter to physically connect the alarm to a PC.

The following is a description of the alarm's configuration software.

Setting of RS-485 transmission:

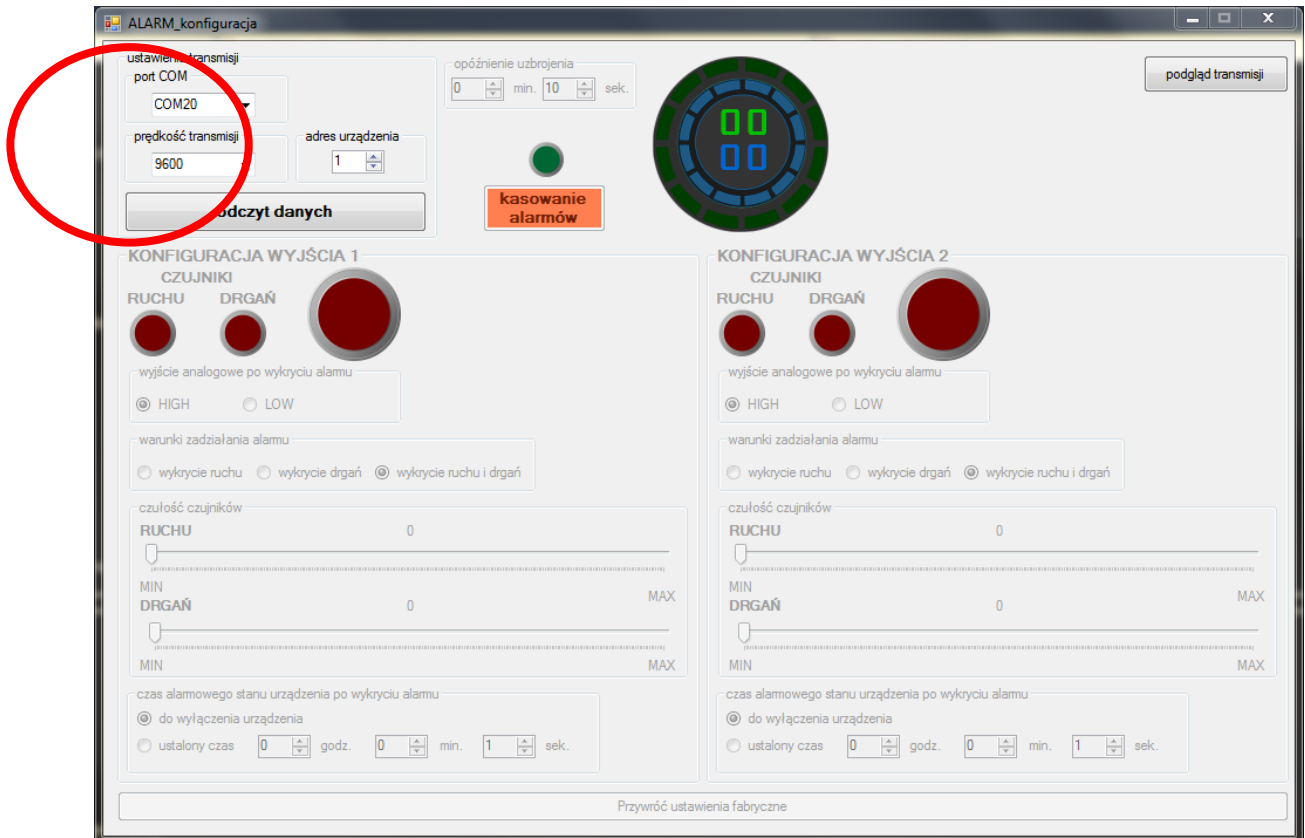

To establish connection with the device, set 3 transmission parameters: device address, transmission speed, and number of the COM port where the device is connected. Default parameters: address-1; transmission speed- 9600, click "read data".



If there is a communication problem, the following message will appear.

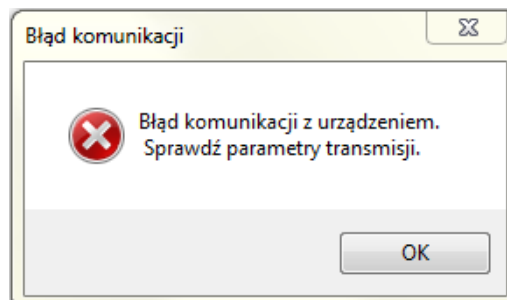

Data read from the device can be activated by pressing (1).

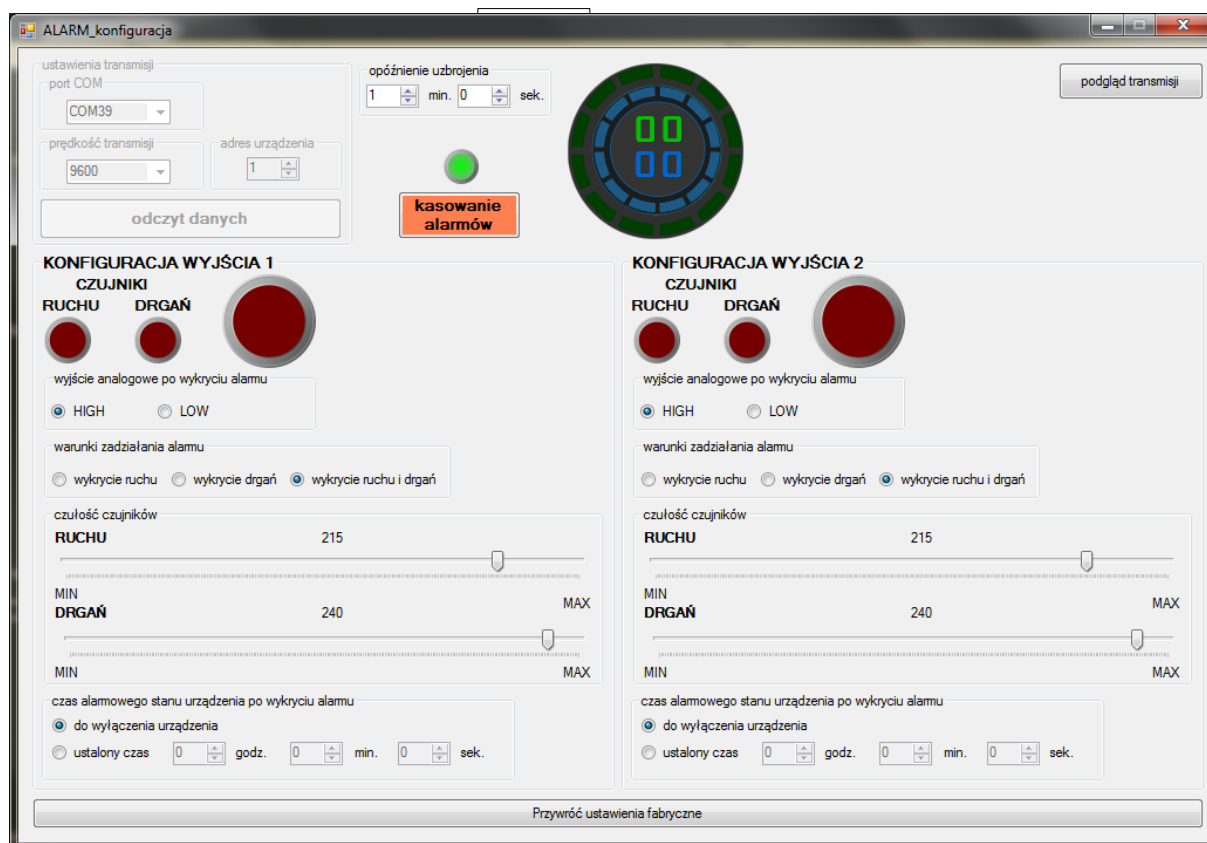

Description of software functions and parameters:

1. Configuration data read from the device.
2. Alarm signaling.
3. Movement or vibration detection signaling.
4. Setting output signal after detecting alarm.
5. Setting the conditions for activating alarm.
6. Setting the sensitivity of movement sensor.
7. Setting the sensitivity of vibration sensor.
8. Setting the duration of alarm signaling.
9. Erasing alarms.
10. Transmission parameters.
11. Setting the time from turning in the device to engaging the alarm.
12. Timer counting down time to engage the alarm.

After reading status and configuration data, all the aforementioned parameters will be set to values read from the device.

Saving configuration settings in the device and reading the status register:

Settings are saved automatically after changing a parameter in the software. In case of numerical values input from the keyboard, the parameter must be confirmed by pressing "Enter".

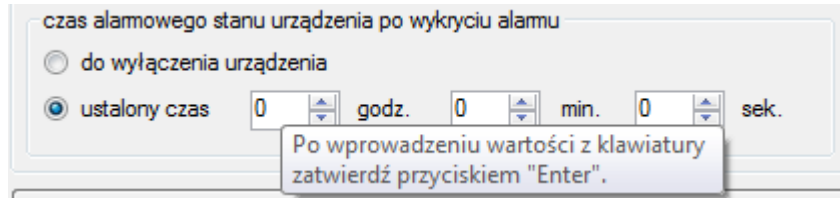

Reading the status register is done periodically; detection of movement, vibration, or activation of alarm is signaled by the software with status lights.

No detection of movement or vibration.



Detection of movement.



Detection of vibration.



Activating alarm.

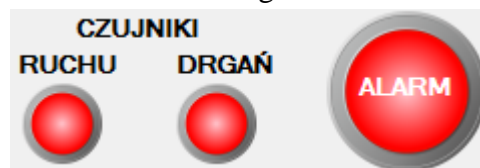

Clicking 'transmission preview' will open a window with a preview of all frames being sent and received.

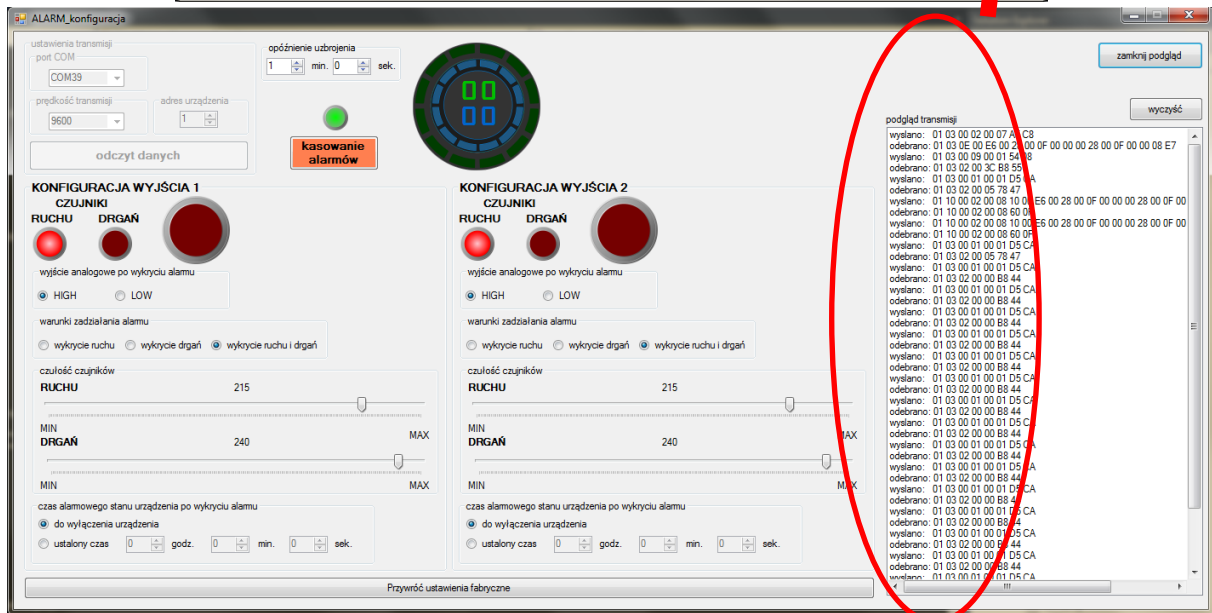
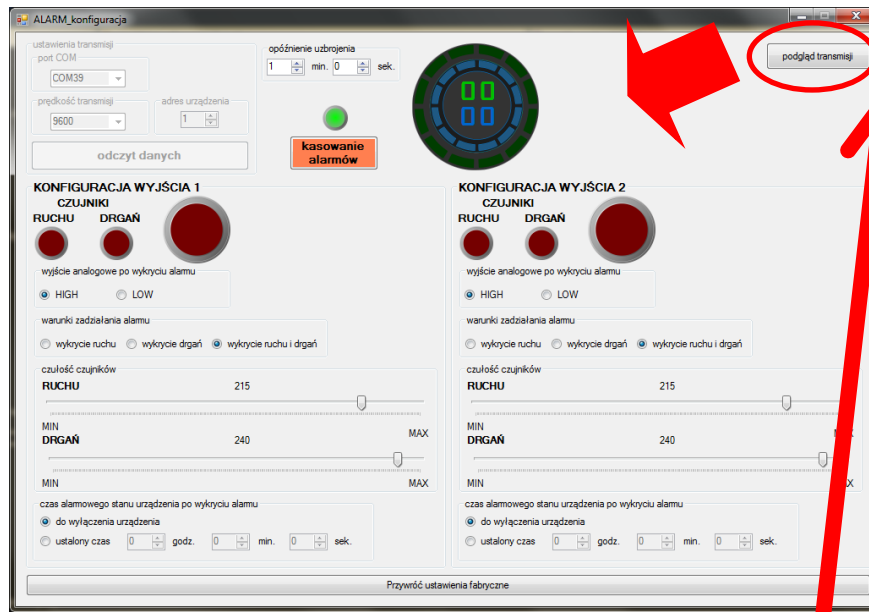

Clicking 'close preview' will hide the preview of all frames being sent and received.

Erasing alarms:

In order to erase active alarms, click 'Erase alarms'. This will start an alarm erasing procedure. After alarms have been erased, the alarm starts its re-engaging procedure, observing the engage delay time.



Green light indicates engaging the alarm.



Returning to default settings:

In order to return to default settings, click 'Return to default settings'.

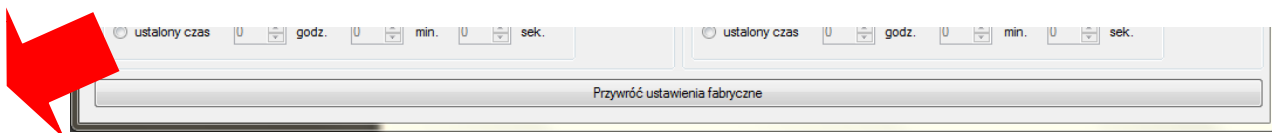

There is a progress bar indicating the progress of bringing back default settings.

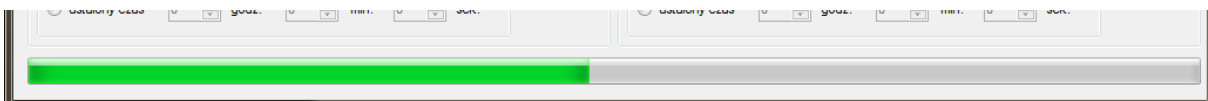

Having returned to default settings, the alarm starts its re-engaging procedure, as in the case of erasing alarms.

2.3. Operating MODBUS RTU protocol

Transmission parameters: 1 start bit, 8 data bits, 1 or 2 stop bits (2 bits are transmitted, transmission with one and two bits is accepted), without parity control

Transmission speed: selected from 1200 to 115200 bit/sec.

Transmission protocol: MODBUS RTU compliant

Device parameters are accessible as HOLDING registers. Use 3h function to read register (or a group of registers), and 10h to save function registers (according to MODBUS RTU protocol specifications). Up to 6 registers (in one frame) can be read or saved with 3h and 10h functions.

If an error occurs when reading or saving one of the registers, the device will return the frame containing error code according to Modbus RTU protocol.

Error code are interpreted in the following manner:

- 01h** - incorrect function number (only 03h, 10h functions acceptable),
- 02h** - incorrect register number for reading or saving,
- 03h** - attempt to save a value out of acceptable range

The following examples of Modbus RTU protocol frames refer to device with address 1. All values are given hexadecimal.

Designation:

ADDR Device address in system

FUNC Function number

REG H,L Senior and junior part of register number, to which the command refers

COUNT H,L Senior and junior part of counter of amount of registers, to which the command refers, beginning with register designated as REG (only value 1 is acceptable)

BYTE C Number of data bytes in frame

DATA H,L Senior and junior part of data words

CRC L,H Junior and senior part of CRC total

1. Frame of query about the value of status register by device with address 1:

ADDR	FUNC	REG H,L		COUNT H,L		CRC L,H	
01	03	00	01	00	01	D5	CA

a) Device response:

ADDR	FUNC	BYTE C	DATA H,L		CRC L,H	
01	03	02	00	03	F8	45

b) Device response (when error is detected):

ADDR	FUNC	ERROR		CRC L,H	
01	83	60		41	18

2. Frame of query about the device type ID code

ADDR	FUNC	REG H,L		COUNT H,L		CRC L,H	
01	03	00	21	00	01	D4	00

Device response:

ADDR	FUNC	BYTE C	DATA H,L		CRC L,H	
01	03	02	09	01	7F	D4

DATA – ID code (0901h)

3. Transfer of data from registers no. 1, 2, 3 (example of transferring a number of registers in one frame):

ADDR	FUNC	REG H,L		COUNT H,L		CRC L,H	
01	03	00	01	00	03	54	0B

Device response:

ADDR	FUNC	BYTE C	DATA H1,L1		DATA H2,L2		DATA H3,L3		CRC L,H	
01	03	06	00	00	00	83	00	28	D0	83



The MODBUS RTU protocol is not fully implemented. Only the aforementioned communication methods are acceptable.

2.4. List of registers

Register	Save	Range	Default value	Description
01h	No			<p>Alarm status register:</p> <p>Bit1:Bit0: For output 1: 00 – no action from sensors; 01 – action from movement sensor; 10 – action from vibration sensor; 11 – action from movement and vibration sensor.</p> <p>Bit3:Bit2 For output 2: 00 – no action from sensors; 01 – action from movement sensor; 10 – action from vibration sensor; 11 – action from movement and vibration sensor.</p> <p>Bit6: 0 – alarm inactive on output 1; 1 – alarm active on output 1.</p> <p>Bit7: 0 – alarm inactive on output 2; 1 – alarm active on output 2.</p>
02h	Yes		E6h	<p>Configuration register:</p> <p>Bit0: 0–output 1 normal: „HI” value after detecting alarm; 1–output 1 inversion: „LO” value after detecting alarm;</p> <p>Bit2:Bit1: 11–signal on output 1 is action from movement and vibration sensor; 01–signal on output 1 is action from movement sensor; 10– signal on output 1 is action from vibration sensor;</p> <p>Bit4: 0–output 2 normal: „HI” value after detecting alarm; 1–output 2 inversion: „LO” value after detecting alarm;</p> <p>Bit6:Bit5: 11– signal on output 2 is action from movement and vibration sensor; 01–signal on output 2 is action from movement sensor; 10–signal on output 2 is action from vibration sensor;</p> <p>Bit7: 0–alarm activated; 1– alarm activated; After switching on power, the alarm is active, bit is set to 1.</p>

03h	Yes	1÷256	28h	Sensitivity of MOVEMENT sensor for output 1
04h	Yes	1÷256	0Fh	Sensitivity of VIBRATION sensor for output 1
05h	Yes	0÷3600	0000h	Timeout for output 1 – the time (in seconds) of action after alarm is triggered. If value is 0 then the triggered alarm runs infinitely.
06h	Yes	1÷256	28h	Sensitivity of MOVEMENT sensor for output 2
07h	Yes	1÷256	0Fh	Sensitivity of VIBRATION sensor for output 2
08h	Yes	0÷3600	0000h	Timeout for output 2 – the time (in seconds) of action after alarm is triggered. If value is 0 then the triggered alarm runs infinitely.
09h	Yes	0÷3600	003Ch	Delay time for engaging the alarm (in seconds), from switching on power, default value is about 60 seconds.
20h ²	Yes	1÷199	01h	Device address
21h	No		0901h	Device ID code
22h ³	Yes	0 ÷ 7	03h	Transmission speed: 0 - 1200 bit/sec.; 1 - 2400 bit/sec.; 2 - 4800 bit/sec.; 3 - 9600bit/sec.; 4 - 19200 bit/sec.; 5 - 38400 bit/sec.; 6 - 57600 bit/sec.; 7 - 115200 bit/sec.

10. TECHNICAL PARAMETERS

10.1. Electrical parameters

Power	8...36V DC
Power consumption	max 0,5 W
Resistance of output load	≥ 10kΩ
Two-state output signal	0 – low: max 10mV DC 1 – high: max U _{zas} – 0,5V DC
Digital output	RS-485 Modbus RTU

10.2. Acceptable working and environmental parameters

Ambient temperature	-30 °C ...80 °C
Relative humidity	up to 98% with condensation

10.2.1. Mechanical resistance

Impact: acc. to PN-EN 60068-2-27, 31
50g/11ms

Sinusoidal vibration: acc. to PN-EN 60068-2-6, Fc test;

Up to 1,6mm; 2...25Hz;
Up to 4g for 25...100Hz;

10.2.2. Insulation resistance

>100MΩ @750V DC

10.2.3. Insulation durability

500V AC (750V DC), 1 min

10.2.4. Housing protection class

acc. to PN-EN 60529:2003 – IP68

10.3. Structure

10.3.1. Housing

Housing material	Aluminum alloy and stainless steel
Dimensions width/length/height	100/70/30 mm

10.3.2. Cable material

Cable	PVC
-------	-----

11. INSPECTION

11.1. Periodical inspection

Periodical inspection must be conducted according to standards in force.

While inspecting, check the condition of electrical connections on clamps (firmness of connections) and the stability of alarm fixing.

11.2. Non-periodical inspection

If the alarm is exposed to mechanical damage, electrical overvoltage or it works improperly – conduct inspection as necessary.

If there is no signal on the transmission line or signal value is incorrect, check the condition of the cable, the condition of connections on clamps, etc. Check if the power voltage value and load resistance is correct.

If the line is functional, check the operation of the alarm.

12. SCRAPPING, DISPOSAL



Used or damaged alarms must be scrapped according to EU Directive (2002/96/EU) on used electrical and electronic equipment, or returned to the producer.

13. ADDITIONAL INFORMATION

The producer retains the right to implement structural and technological alterations that do not impair the alarm's parameters.

